

1/4 SIZE DETAILS

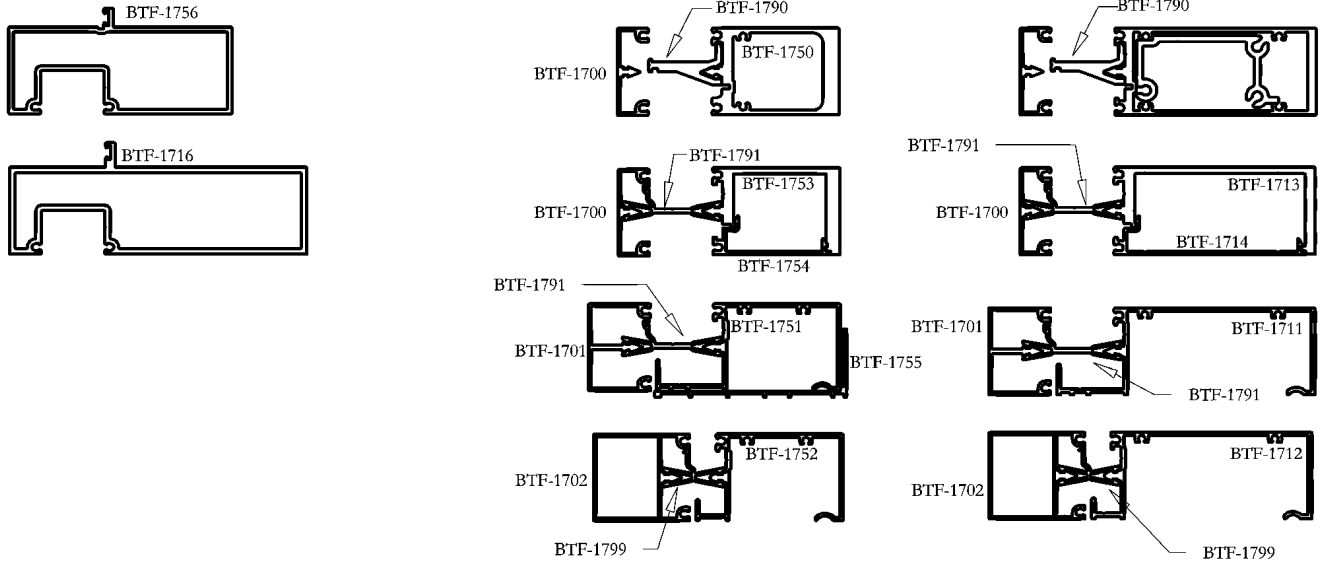

THIS SYSTEM IS DESIGNED TO BE ASSEMBLED WITH #8 SCREWS IN THE SPLINE RACEWAYS AND #10 SCREWS WHEN USING THE SHEAR BLOCKS.

GASKET

REED RUBBER PRODUCTS

800-325-9698

3667

MULLION GASKET (INTERIOR & EXTERIOR)

DOOR PILE

SCHLEGEL CORP.
800-828-6237

AS SELECTED

USED WITH BTF-1716 & BTF-1716

AMESBURY GROUP INC.
704-878-6892

AS SELECTED

USED WITH BTF-1716 & BTF-1756

NYLON CLIPS FOR 1" GLASS MAY BE OBTAINED FROM :

TELAR INDUSTRIES
15720 LINCOLN ST. N. E.
HAM LAKE, MN. 55304
TELE # 612-434-4788
FAX # 612-434-4789







NO TEST DATA AVAILABLE
TREDEGAR EXTRUSIONS INC. DOES NOT MAKE ANY WARRANTY EXPRESS OR IMPLIED INCLUDING
NO WARRANTY OF MERCHANTABILITY OR FITNESS FOR A PARTICULAR PURPOSE AND RESERVES
THE RIGHT TO MAKE CHANGES
REPRODUCTION RIGHTS RESERVED

PRICING FACTORS
1 3/4" FRAMING
BTF-1700 SERIES

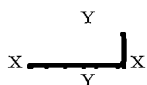
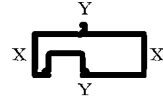

WEIGHT PER FT	EST PER	FACTOR	CAVITY AREA	PART NUMBER	STRUCTURAL VALUES			1/8 SIZE DETAILS
					X-X	Y-Y		
0.324	8.135	25	N/A	BTF1700	0.011	I	0.097	
					0.029	S	0.111	
0.467	12.044	26	N/A	BTF1701	0.142	I	0.071	
					0.162	S	0.103	
0.581	10.740	28	N/A	BTF1702	0.210	I	0.205	
					0.240	S	0.195	
1.686	13.997	16	N/A	BTF1710	0.641	I	3.335	
					0.733	S	1.558	
1.006	22.170	22	N/A	BTF1711	0.374	I	2.683	
					0.372	S	1.028	
0.907	20.131	22	N/A	BTF1712	0.306	I	2.108	
					0.279	S	0.902	
1.361	15.185	11	N/A	BTF1713	0.273	I	2.859	
					0.215	S	1.221	
0.410	10.734	26	N/A	BTF1714	0.011	I	0.560	
					0.017	S	0.247	
2.312	19.256	15	N/A	BTF1716	0.975	I	7.546	
					0.747	S	2.349	
0.974	12.987	13	N/A	BTF1719	0.188	I	0.834	
					0.207	S	0.574	
1.801	10.792	10	N/A	BTF1750	0.557	I	1.408	
					0.634	S	0.903	
0.786	19.386	25	N/A	BTF1751	0.281	I	0.907	
					0.292	S	0.458	
0.707	17.315	24	N/A	BTF1752	0.232	I	0.642	
					0.221	S	0.422	
1.273	12.223	10	N/A	BTF1753	0.261	I	1.039	
					0.226	S	0.616	
0.299	7.861	26	N/A	BTF1754	0.010	I	0.148	
					0.016	S	0.103	

WEIGHT PER FT	EST PER	FACTOR	CAVITY AREA	PART NUMBER	STRUCTURAL VALUES			1/8 SIZE DETAILS
					X-X	I	Y-Y	
0.389	11.256	29	N/A	BTF1755	0.037	I	0.551	
					0.033	S	0.231	
1.649	16.050	18	N/A	BTF1756	0.646	I	3.098	
					0.545	S	1.298	
0.461	5.150	11	N/A	BTF1790	0.010	I	0.069	
					0.020	S	0.079	
0.313	8.266	26	N/A	BTF1791	0.006	I	0.092	
					0.012	S	0.086	
0.222	6.590	30	N/A	BTF1799	0.006	I	0.022	
					0.012	S	0.034	

WINDLOAD CHARTS
1 3/4" FRAMING
BTF-1700 SERIES

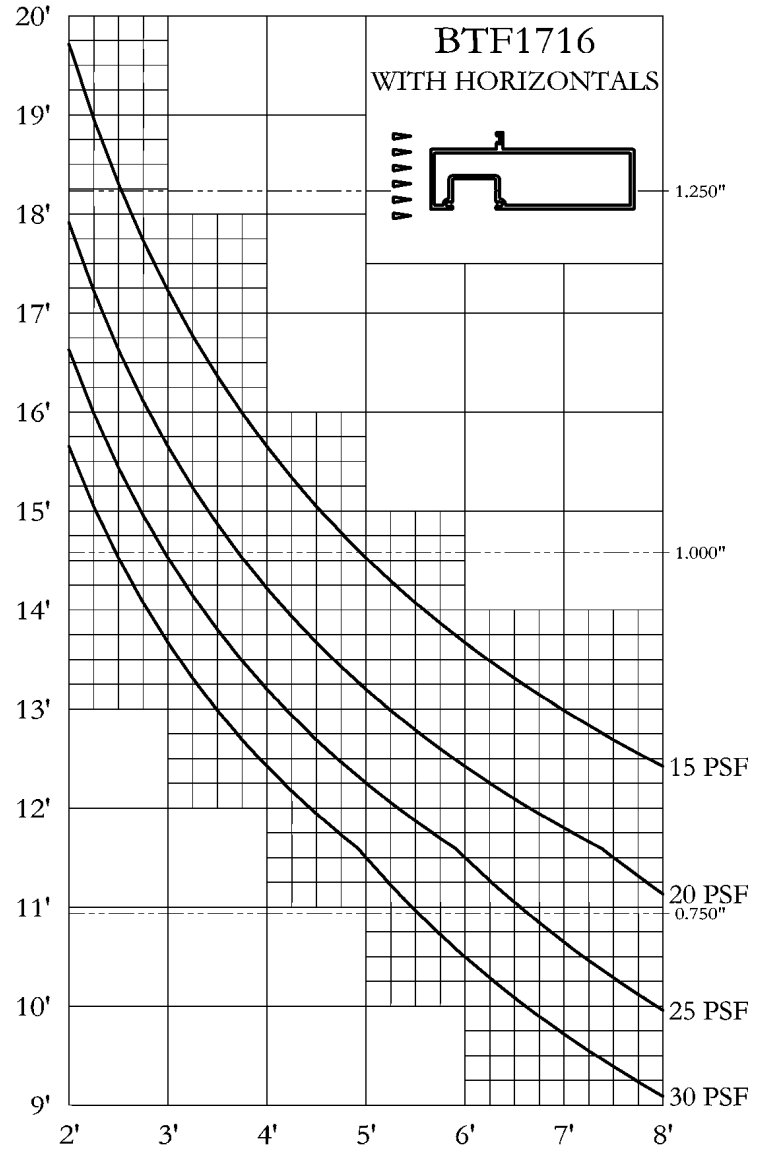
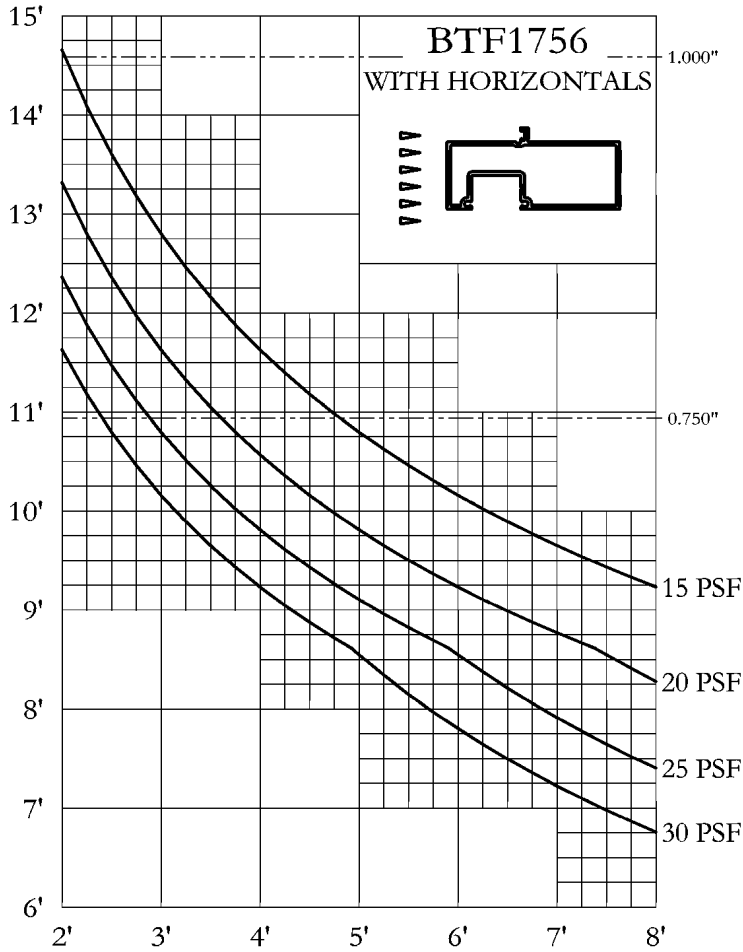

#1 THESE WINDLOAD CHARTS ARE BASED UPON THE LESSER OF DEFLECTION RATIO ($L/175$) OR STRESS (12667)

#2 THESE STRUCTURAL CURVES ARE ESTIMATES AND ARE PRESENTED TO THE BEST KNOWLEDGE OF THE WILLIAM L BONNELL CO. IT IS, HOWEVER, THE RESPONSIBILITY OF THE CUSTOMER TO BE SATISFIED THAT THE CURVES ARE CORRECT. THE WILLIAM L BONNELL CO. MAY NOT BE HELD RESPONSIBLE IN ANY WAY FOR THE FAILURE OF PERFORMANCE RESULTING FROM THE USE OF THESE CURVES.

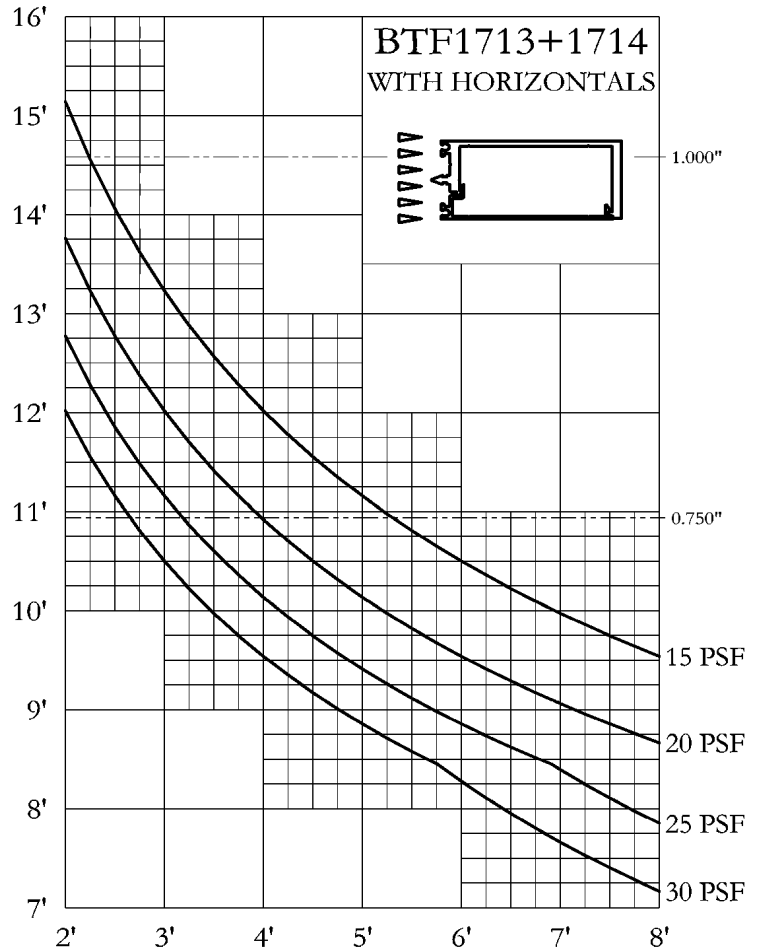
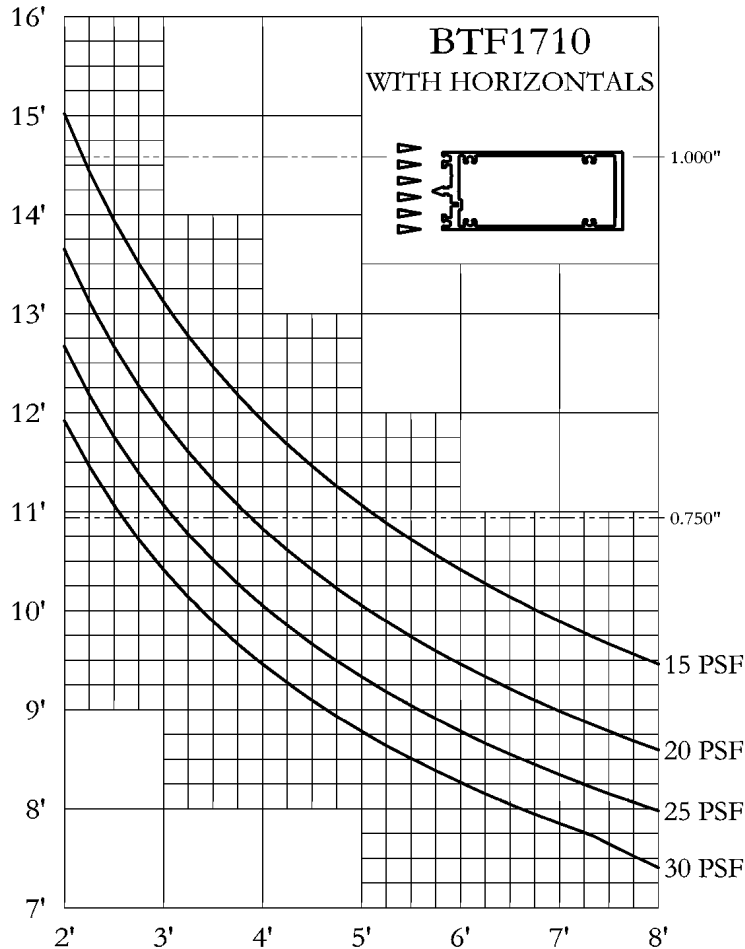
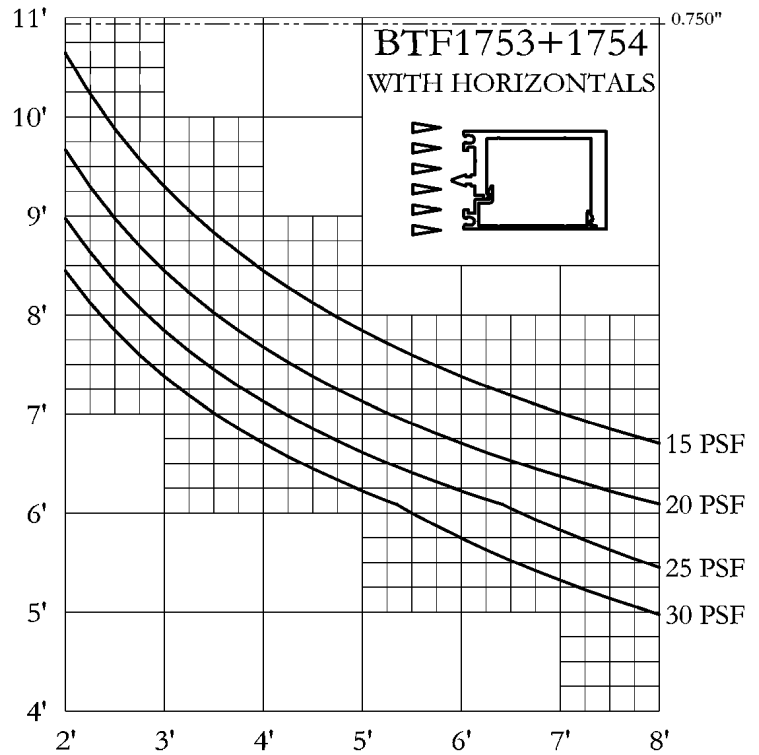
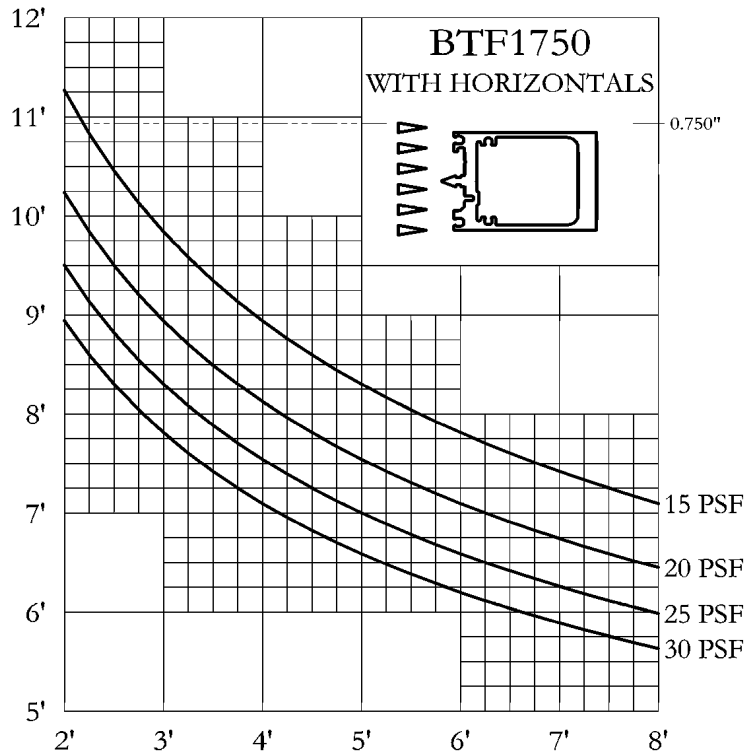

#1 THESE WINDLOAD CHARTS ARE BASED UPON THE LESSER OF DEFLECTION RATIO ($L/175$) OR STRESS (12667)

#2 THESE STRUCTURAL CURVES ARE ESTIMATES AND ARE PRESENTED TO THE BEST KNOWLEDGE OF THE WILLIAM L BONNELL CO. IT IS, HOWEVER, THE RESPONSIBILITY OF THE CUSTOMER TO BE SATISFIED THAT THE CURVES ARE CORRECT. THE WILLIAM L BONNELL CO. MAY NOT BE HELD RESPONSIBLE IN ANY WAY FOR THE FAILURE OF PERFORMANCE RESULTING FROM THE USE OF THESE CURVES.

DETAIL SHEET
1 3/4" DOOR FRAMING
BTF-1700 SERIES



FULL SIZE DETAILS

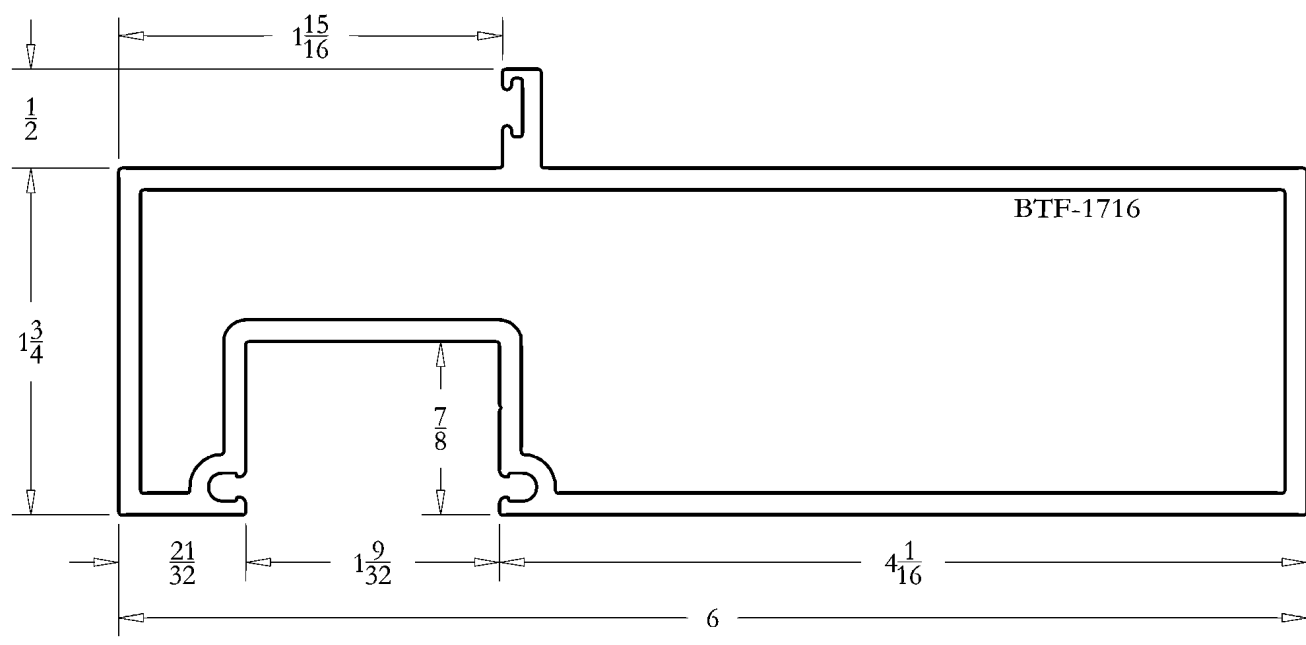
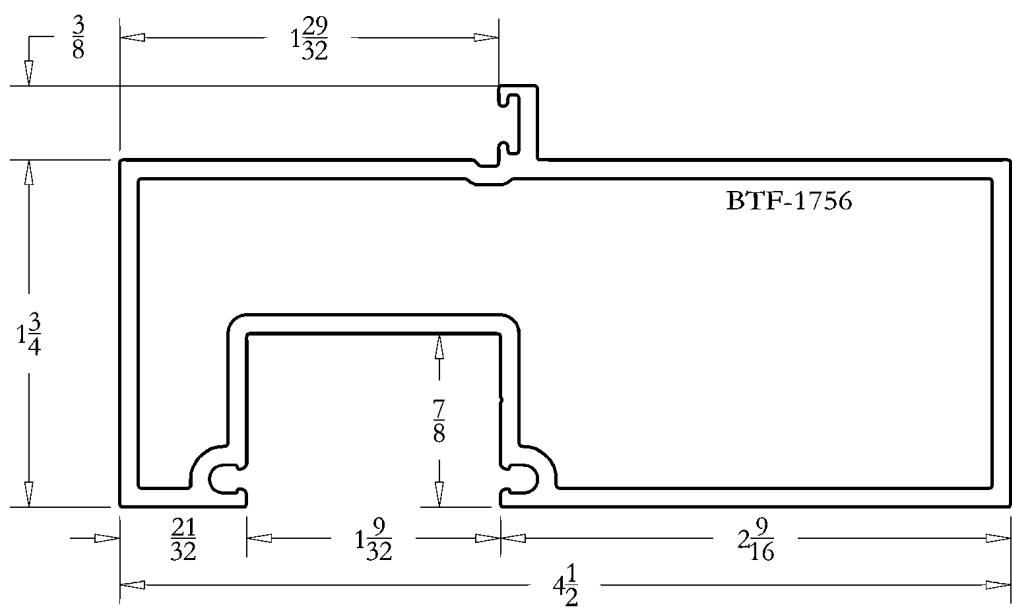

FULL SIZE DETAILS

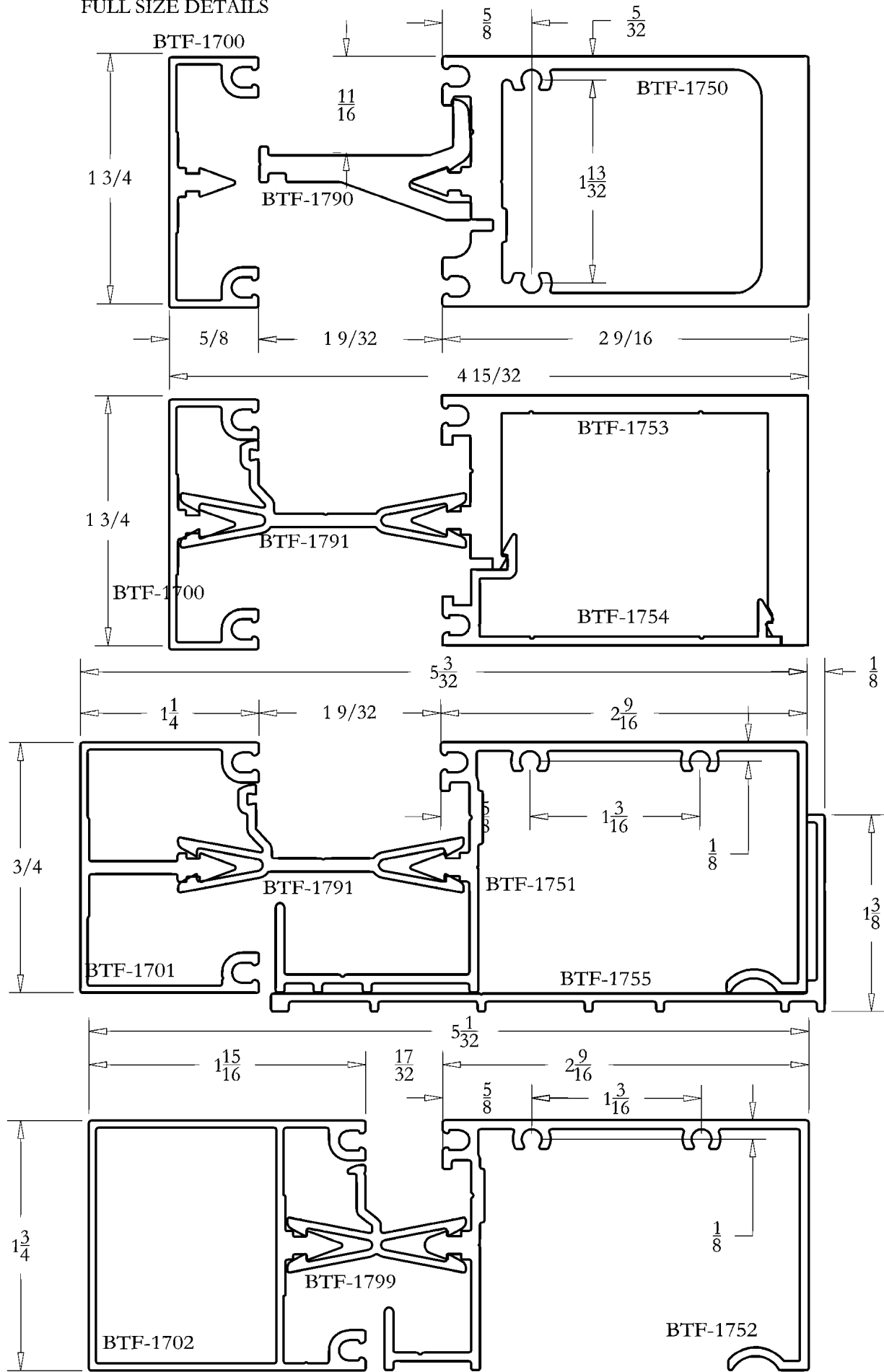

DETAIL SHEET
1 3/4" FRAMING
BTF-1700 SERIES



FULL SIZE DETAILS

