















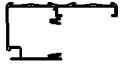

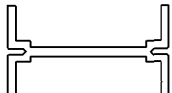



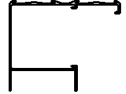

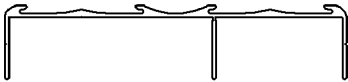





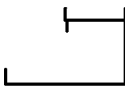

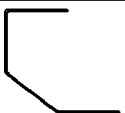

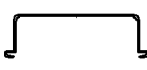
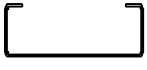
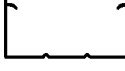
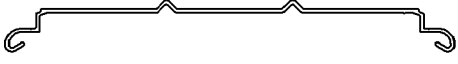

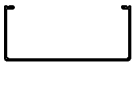
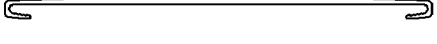
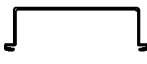







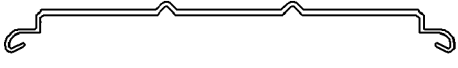

PART NUMBER	DIE DRAWING	WT/FT	PERMIETER	X-X Y-Y
VMP-123		0.934	24.744	1.142 I 2.184 0.598 S 0.683
VMP-157		2.353	27.836	1.154 I 16.293 0.769 S 4.655
VMP-158		2.834	30.447	1.599 I 36.845 0.878 S 7.369
VMP-159		4.230	27.321	3.245 I 37.396 1.571 S 9.349
VMP-164		1.334	22.538	3.152 I 0.777 1.576 S 0.518
WLB-507		0.674	18.521	0.767 I 0.703 0.416 S 0.342
WLB-508		1.255	29.489	1.154 I 2.663 0.658 S 0.798
WLB-509		0.640	16.490	0.034 I 1.905 0.036 S 0.692
WLB-510		0.946	11.821	0.795 I 0.072 0.605 S 0.096
WLB-511		0.870	22.710	0.747 I 1.199 0.447 S 0.429
WLB-512		0.380	12.617	0.008 I 0.697 0.015 S 0.324
WLB-513		2.452	27.048	0.707 I 15.354 0.471 S 4.387
WLB-518		0.978	26.370	1.735 I 1.644 0.612 S 0.727
WLB-520		1.502	31.275	2.993 I 3.653 1.047 S 1.071

PART NUMBER	DIE DRAWING	WT/FT	PERMIETER	X-X	Y-Y
WLB-521		0.818	18.108	0.704 I 1.199	0.346 S 0.779
WLB-522		0.827	18.594	0.058 I 2.319	0.064 S 0.822
WLB-523		1.752	31.110	3.484 I 8.162	1.510 S 1.806
WLB-524		2.588	37.850	5.250 I 16.697	2.019 S 4.309
WLB-525		2.398	35.052	12.937 I 9.809	3.854 S 2.166
WLB-528		2.093	34.679	3.382 I 10.853	1.585 S 2.726
WLB-529		1.432	31.944	2.212 I 5.670	1.088 S 1.307
WLB-531		1.229	28.484	2.068 I 3.580	0.895 S 0.934
WLB-533		0.504	16.738	0.079 I 0.971	0.067 S 0.382
WLB-536		1.914	29.172	9.299 I 5.898	2.908 S 1.291
WLB-540		1.411	26.336	0.957 I 8.402	0.482 S 2.461
WLB-542		1.045	22.659	0.466 I 5.232	0.315 S 1.513
WLB-551		1.690	25.777	1.252 I 9.585	0.711 S 2.865
WLB-560		0.949	25.915	0.822 I 4.628	0.414 S 1.543

PART NUMBER	DIE DRAWING	WT/FT	PERMIETER	X-X	Y-Y
WLB-561		0.649	18.036	0.021 I 2.953 0.038 S 0.811	
WLB-574		3.120	34.593	7.430 I 12.836 3.715 S 3.737	
WLB-575		3.611	35.978	8.167 I 16.522 4.083 S 5.437	
WLB-576		1.135	24.032	0.852 I 5.621 0.453 S 1.850	
WLB-577		0.792	16.013	0.003 I 2.926 0.012 S 0.847	
WLB-578		1.043	22.830	0.463 I 5.223 0.314 S 1.510	
WLB-579		4.817	43.775	11.633 I 35.860 5.817 S 8.633	
WLB-580		1.380	28.450	1.772 I 7.554 0.751 S 2.194	
WLB-582		2.324	30.571	4.847 I 4.847 2.424 S 2.422	
WLB-583		3.726	40.383	16.271 I 19.021 4.506 S 6.340	
WLB-584		1.992	24.063	3.551 I 2.718 1.713 S 1.812	
WLB-590		5.028	45.702	23.624 I 23.624 7.875 S 7.875	
WLB-594		0.731	17.438	0.035 I 2.838 0.041 S 0.883	
WLB-595		2.158	35.100	5.385 I 9.197 2.693 S 3.028	

PART NUMBER	DIE DRAWING	WT/FT	PERMIETER	X-X	Y-Y
WLB-596		1.247	25.717	1.066 I 6.029 0.538 S 2.010	
WLB-597		1.238	26.419	1.126 I 6.168 0.598 S 2.056	
WLB-598		0.809	17.984	0.023 I 3.422 0.041 S 0.940	
WLB-599		0.751	18.220	0.021 I 3.306 0.038 S 0.909	
WLB-600		3.160	35.587	7.274 I 13.638 3.637 S 4.094	
WLB-601		3.646	41.949	9.125 I 25.503 4.563 S 5.605	
WLB-602		2.766	36.239	6.765 I 14.580 2.915 S 2.919	
WLB-603		1.574	28.619	0.489 I 11.182 0.235 S 2.366	
WLB-604		1.795	28.602	3.998 I 6.282 1.669 S 1.705	
WLB-605		4.212	46.371	20.022 I 20.022 6.674 S 6.674	
WLB-606		3.664	39.221	14.728 I 20.007 4.908 S 5.620	

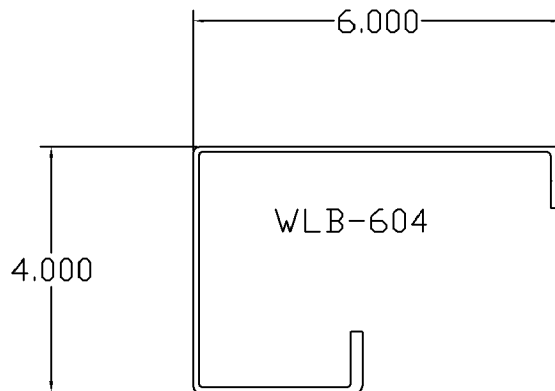
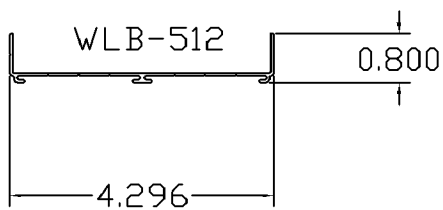
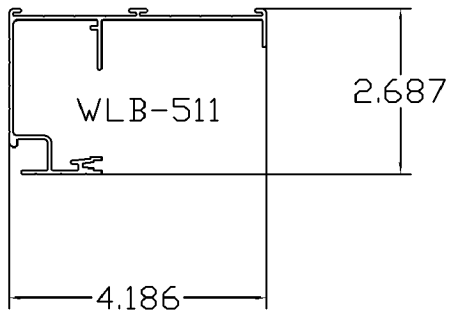
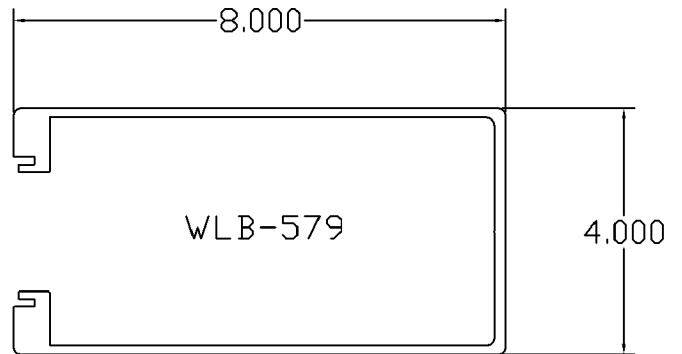
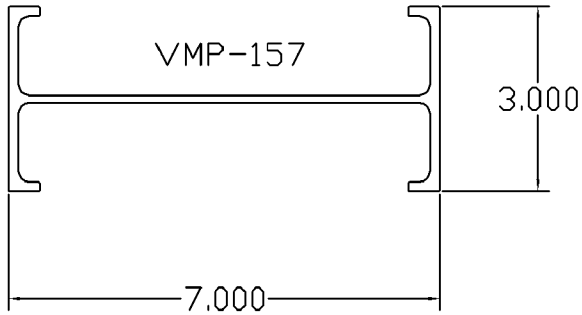
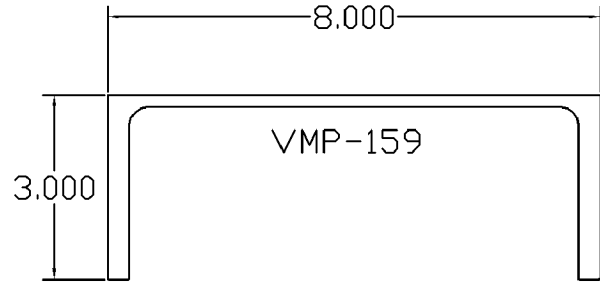
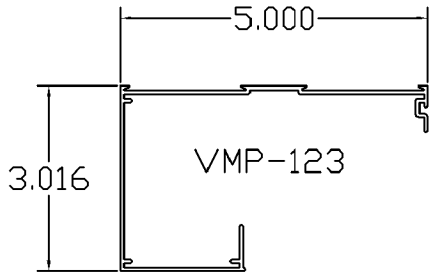

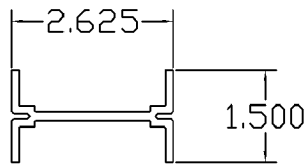

WLB-510

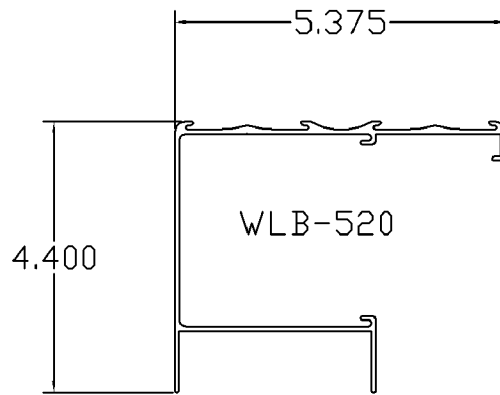

WLB-520

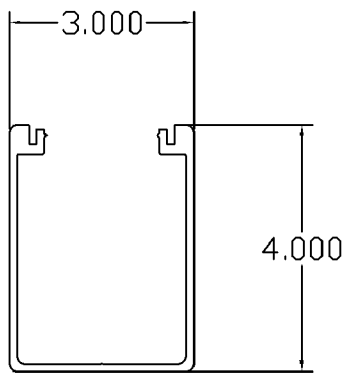

WLB-584

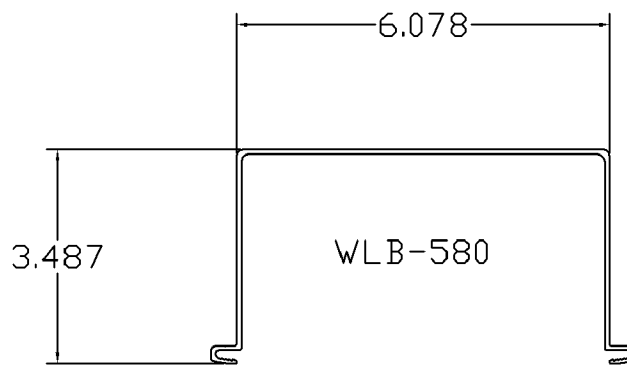

WLB-580

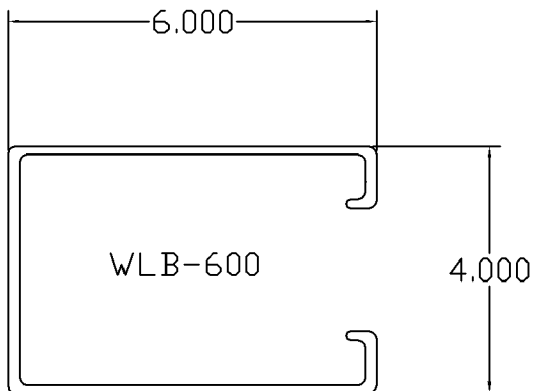

WLB-600

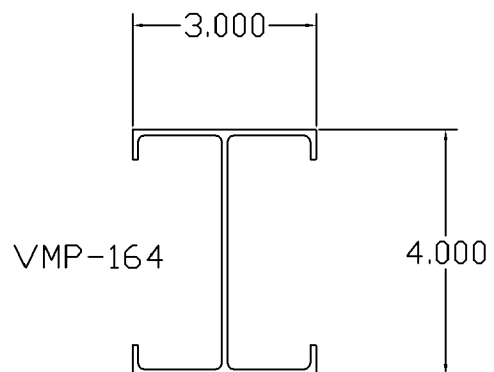

VMP-164

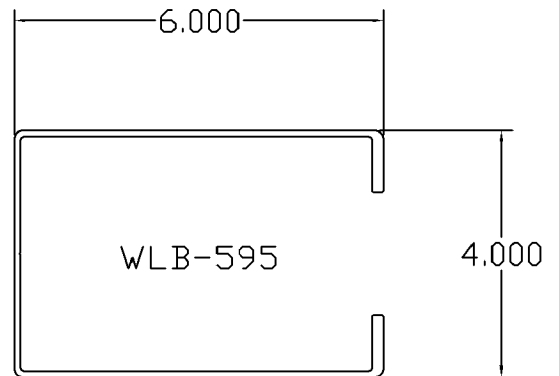
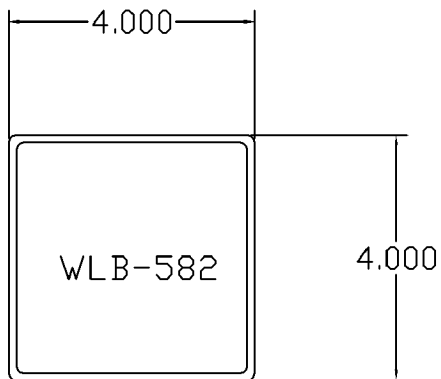
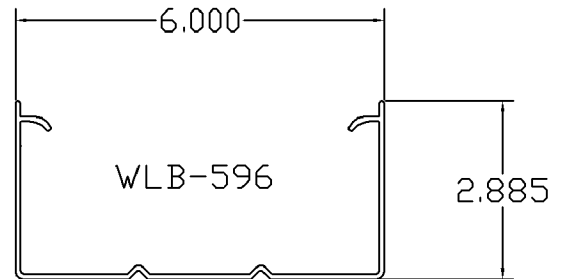
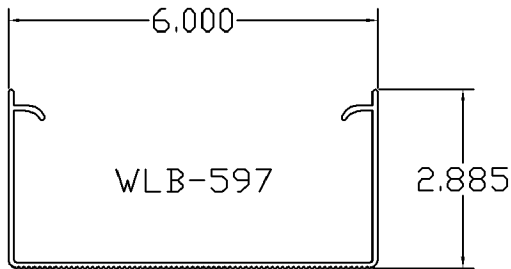
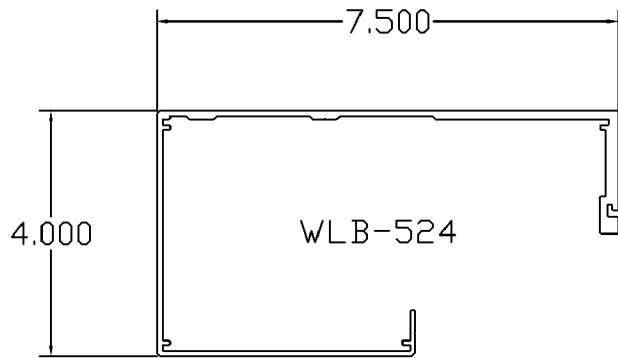
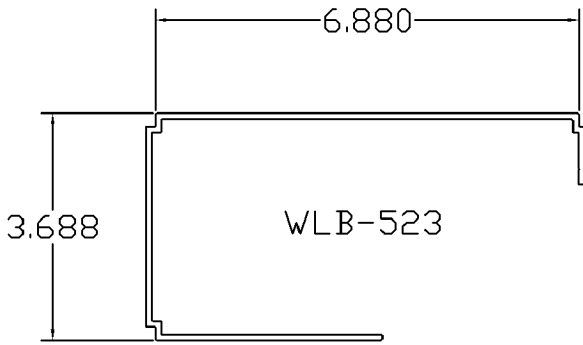

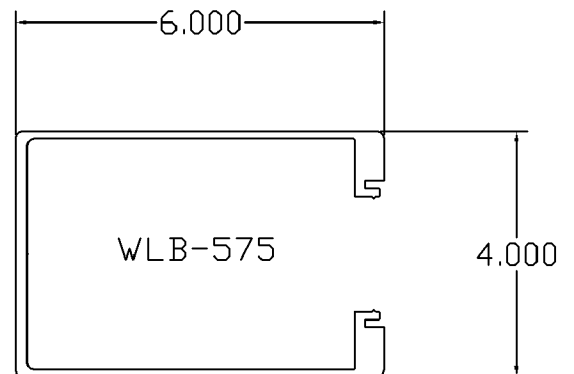
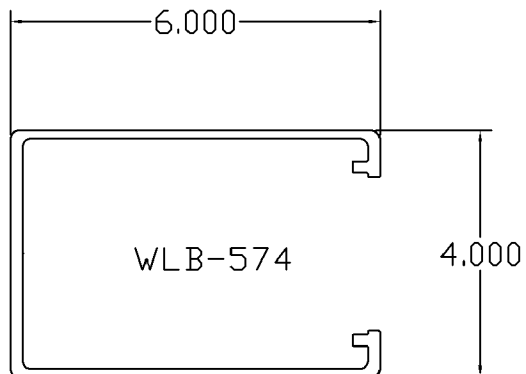
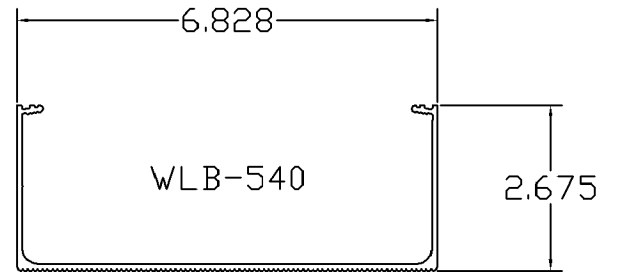
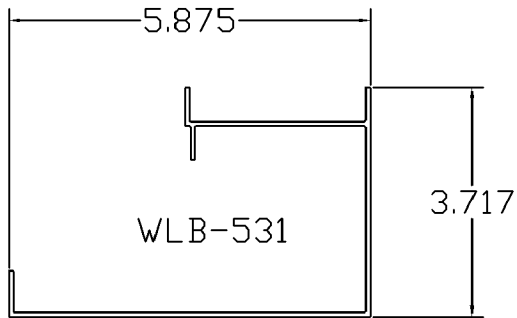
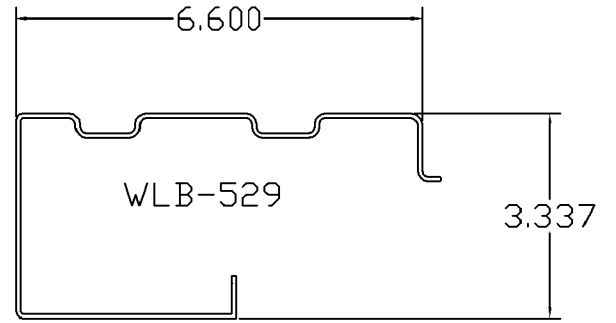
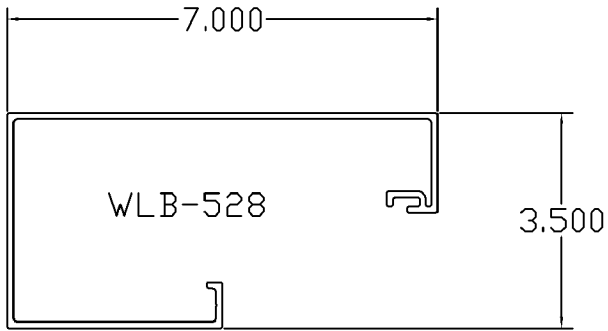

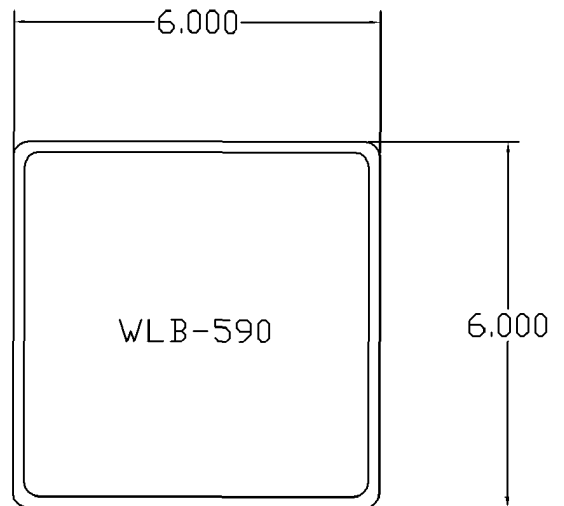
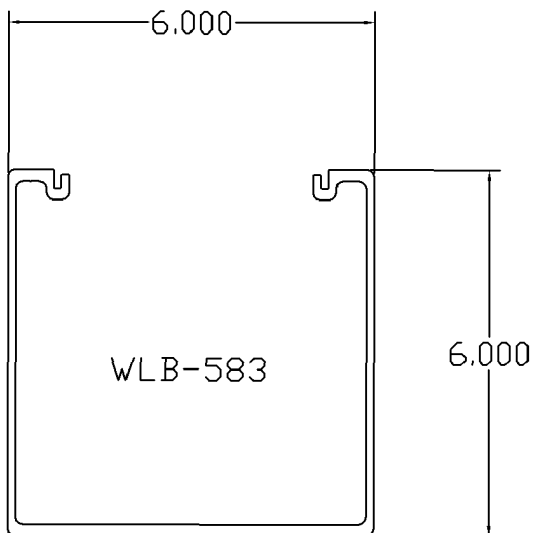
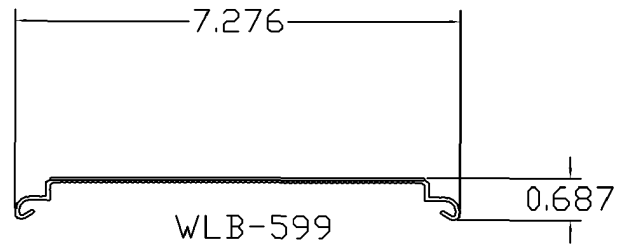
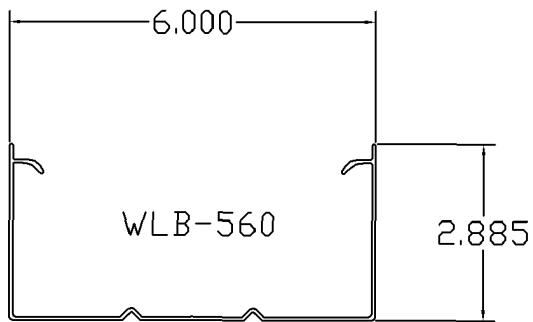
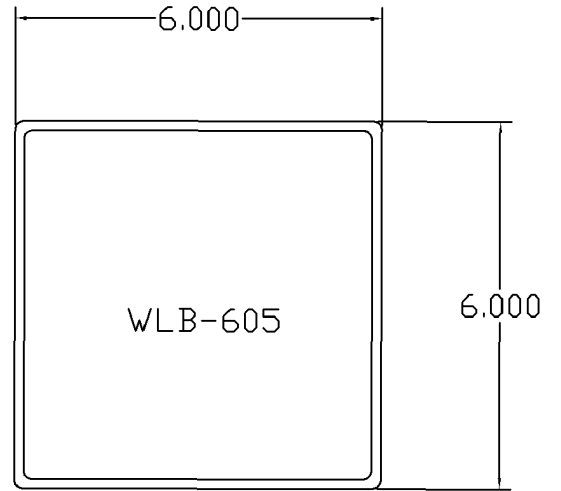
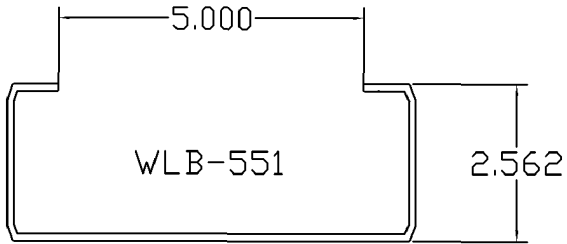

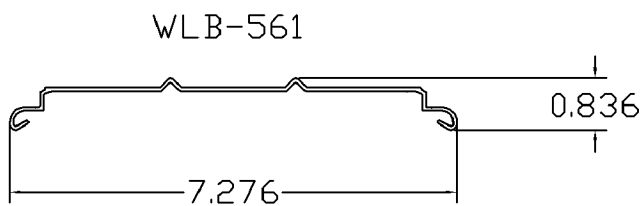
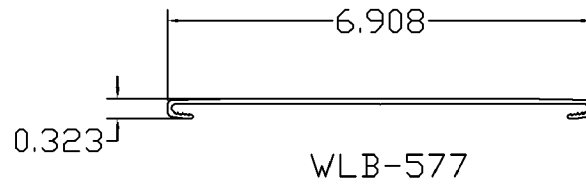
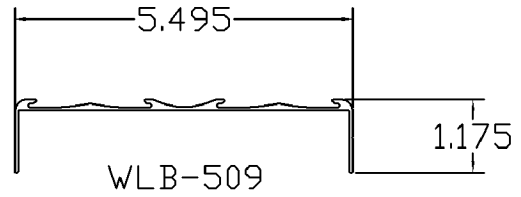
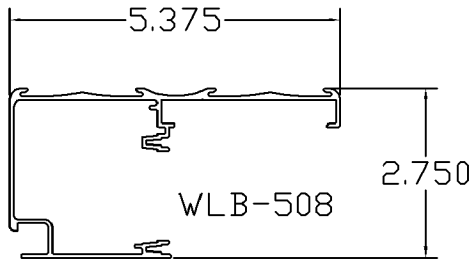
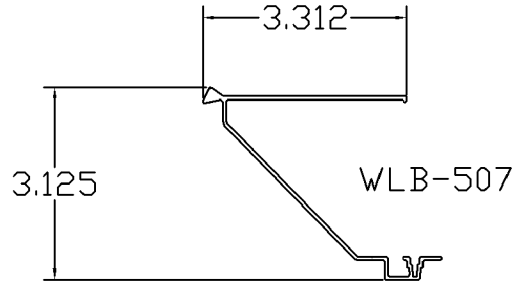

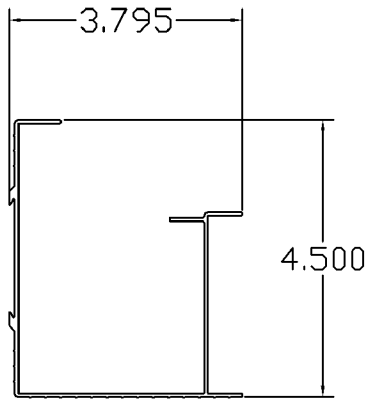

WLB-518

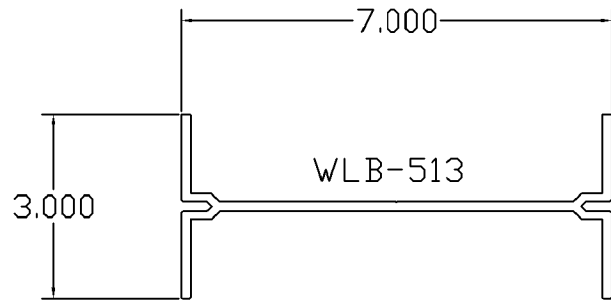

WLB-513

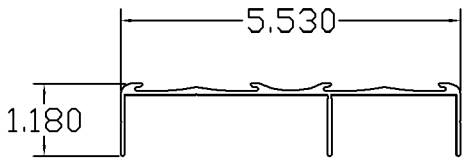

WLB-522

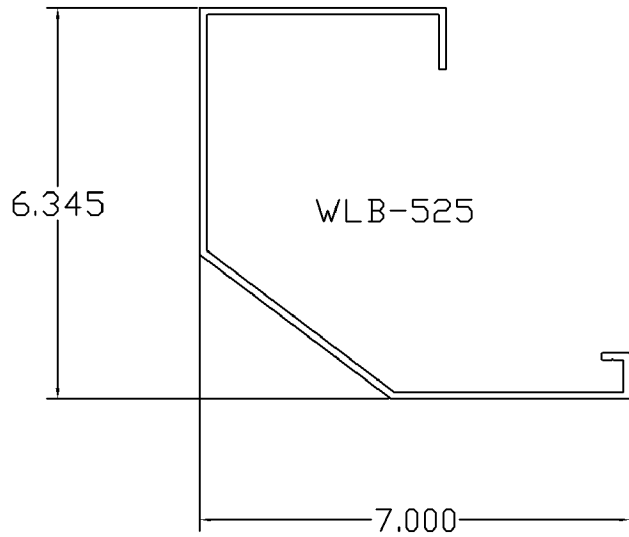

WLB-525

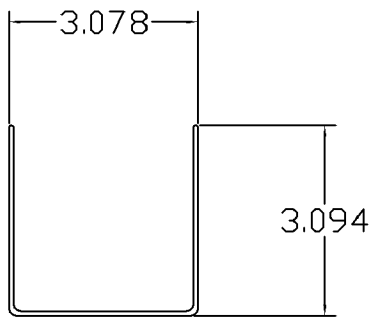

WLB-521

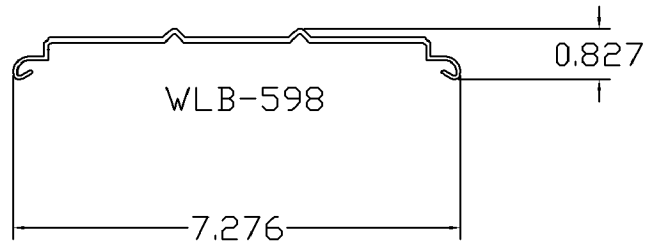

WLB-598

