

1/4 SIZE DETAILS

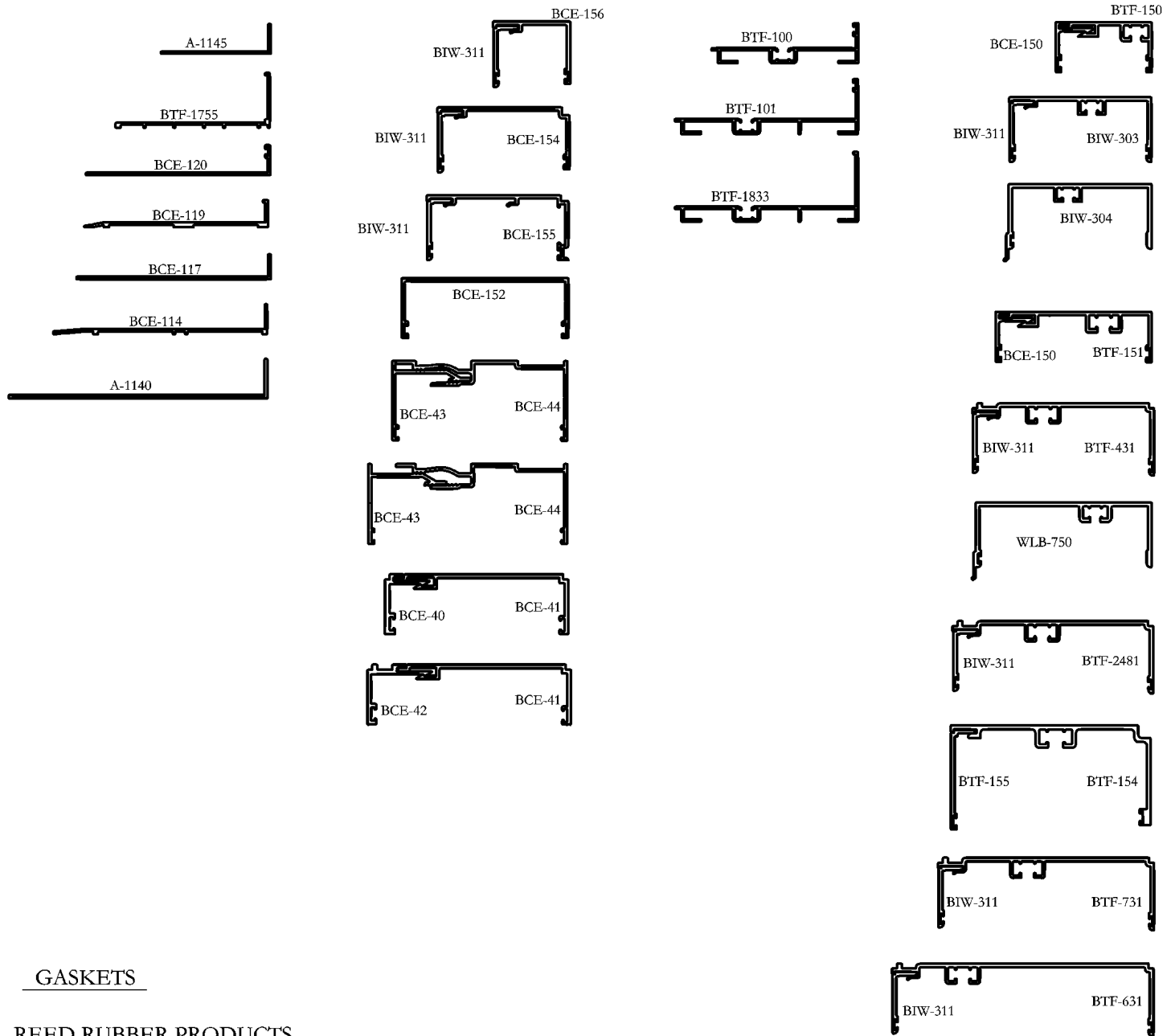

GASKETS



REED RUBBER PRODUCTS  
800-325-9698

NO TEST DATA AVAILABLE  
TREDEGAR EXTRUSIONS INC. DOES NOT MAKE ANY WARRANTY EXPRESS OR IMPLIED INCLUDING  
NO WARRANTY OF MERCHANTABILITY OR FITNESS FOR A PARTICULAR PURPOSE AND RESERVES  
THE RIGHT TO MAKE CHANGES  
REPRODUCTION RIGHTS RESERVED

**PRICING FACTORS  
RECEPTORS AND  
FLASHING**

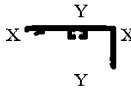
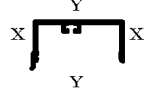

WEIGHT PER FT	EST PER	FACTOR	CAVITY AREA	PART NUMBER	STRUCTURAL VALUES			1/8 SIZE DETAILS
					X-X	Y-Y		
0.694	14.949	22	N/A	A1140	0.021	I	2.429	
					0.023	S	0.666	
0.256	6.982	27	N/A	A1145	0.007	I	0.169	
					0.011	S	0.103	
0.371	6.290	17	N/A	BCE40	0.022	I	0.069	
					0.025	S	0.079	
0.736	13.957	19	N/A	BCE41	0.099	I	1.308	
					0.081	S	0.501	
0.419	7.519	18	N/A	BCE42	0.073	I	0.070	
					0.072	S	0.059	
0.407	8.911	22	N/A	BCE43	0.102	I	0.141	
					0.078	S	0.102	
0.773	16.684	22	N/A	BCE44	0.160	I	1.244	
					0.102	S	0.492	
0.474	12.592	27	N/A	BCE114	0.006	I	1.116	
					0.010	S	0.374	
0.404	10.982	27	N/A	BCE117	0.004	I	0.780	
					0.007	S	0.290	
0.504	10.863	22	N/A	BCE119	0.006	I	0.848	
					0.010	S	0.324	
0.403	11.097	28	N/A	BCE120	0.009	I	0.728	
					0.014	S	0.275	
0.227	5.281	23	N/A	BCE150	0.013	I	0.024	
					0.018	S	0.029	
0.684	15.239	22	N/A	BCE152	0.131	I	1.494	
					0.117	S	0.713	
0.491	10.983	22	N/A	BCE154	0.077	I	0.523	
					0.062	S	0.256	
0.580	13.050	23	N/A	BCE155	0.111	I	0.668	
					0.086	S	0.298	

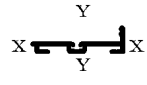
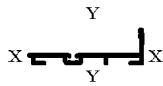
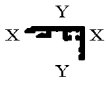
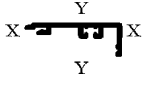
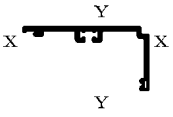
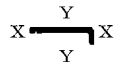
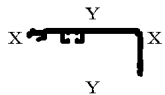
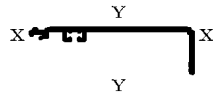
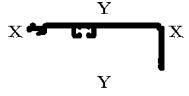
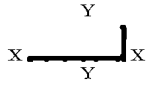
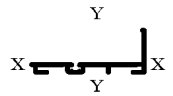
WEIGHT PER FT	EST PER	FACTOR	CAVITY AREA	PART NUMBER	STRUCTURAL VALUES			1/8 SIZE DETAILS
					X-X	I	Y-Y	
0.421	8.342	20	N/A	BCE156	0.076	I	0.145	
					0.064	S	0.112	
0.676	13.811	20	BB	BIW303	0.090	I	0.715	
					0.067	S	0.323	
0.894	16.748	19	BB	BIW304	0.227	I	1.418	
					0.157	S	0.746	
0.221	4.608	21	N/A	BIW311	0.004	I	0.043	
					0.008	S	0.045	
0.510	13.947	27	BBS	BTF100	0.018	I	0.630	
					0.025	S	0.308	
0.629	17.119	27	BBS	BTF101	0.041	I	1.233	
					0.039	S	0.477	
0.486	10.786	22	CCS	BTF150	0.038	I	0.204	
					0.039	S	0.138	
0.677	14.895	22	DD	BTF151	0.045	I	0.786	
					0.044	S	0.350	
1.139	19.392	17	EE	BTF154	0.522	I	2.476	
					0.266	S	0.790	
0.329	6.601	20	N/A	BTF155	0.004	I	0.170	
					0.008	S	0.119	
0.856	17.084	20	DD	BTF431	0.129	I	1.627	
					0.085	S	0.628	
1.078	21.117	20	DDS	BTF631	0.138	I	4.315	
					0.088	S	1.214	
0.950	18.853	20	DD	BTF731	0.133	I	2.502	
					0.087	S	0.819	
0.389	11.256	29	N/A	BTF1755	0.037	I	0.551	
					0.033	S	0.231	
0.653	17.626	27	BBS	BTF1833	0.077	I	1.311	
					0.056	S	0.493	

PRICING FACTORS  
RECEPTORS AND  
FLASHING



WEIGHT PER FT	EST PER	FACTOR	CAVITY AREA	PART NUMBER	STRUCTURAL VALUES			1/8 SIZE DETAILS
					X-X		Y-Y	
0.907	18.071	20	DD	BTF2481	0.131	I	2.046	
					0.086	S	0.713	
1.036	18.673	18	CC	WLB750	0.241	I	2.338	
					0.162	S	0.998	

FULL SIZE DETAILS

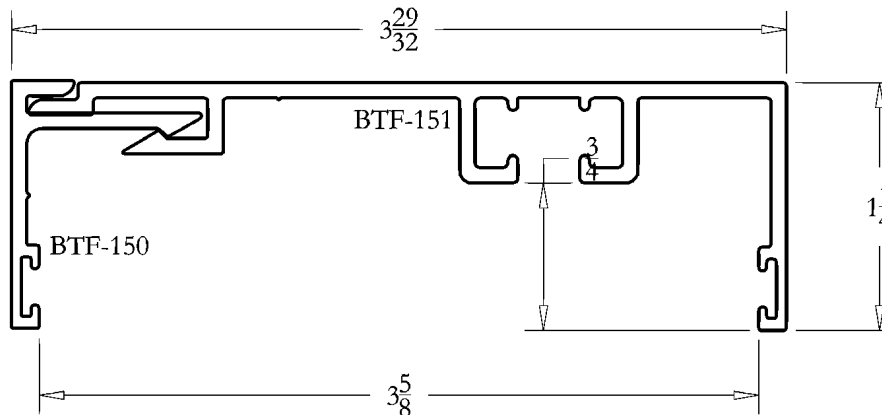
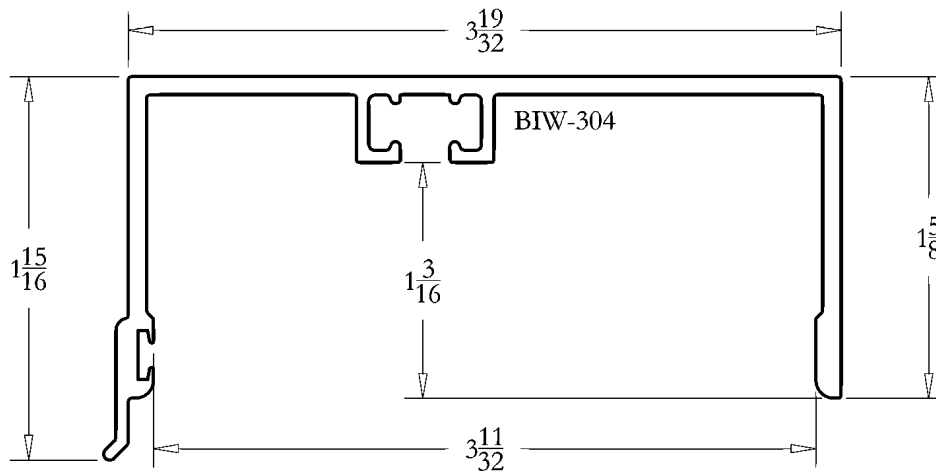
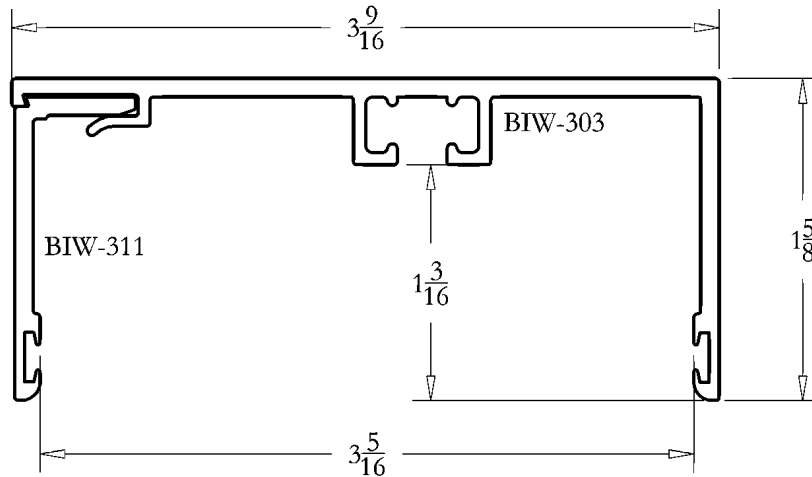
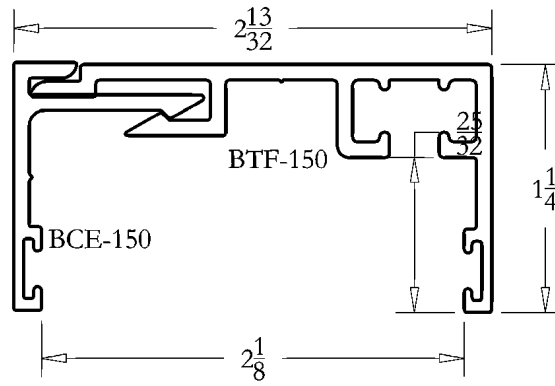

# DETAIL SHEET RECEPTORS AND FLASHING



## FULL SIZE DETAILS

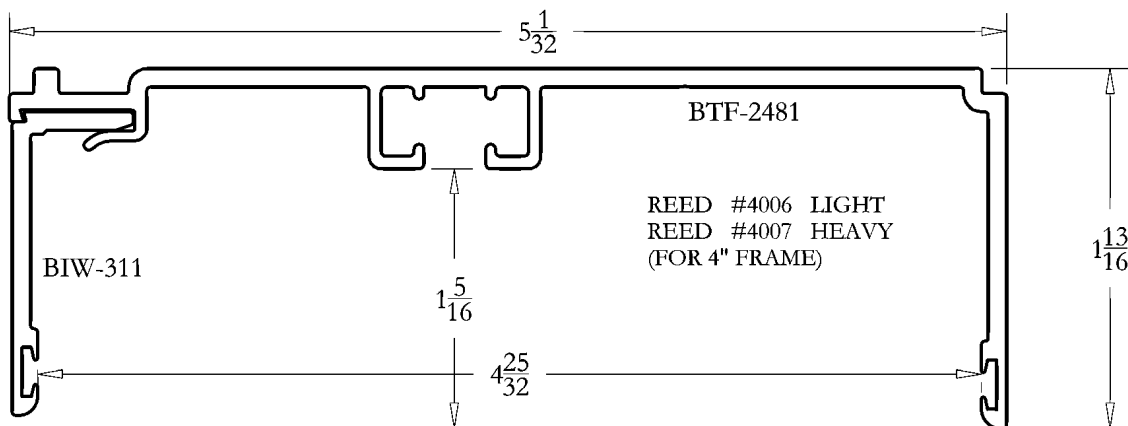
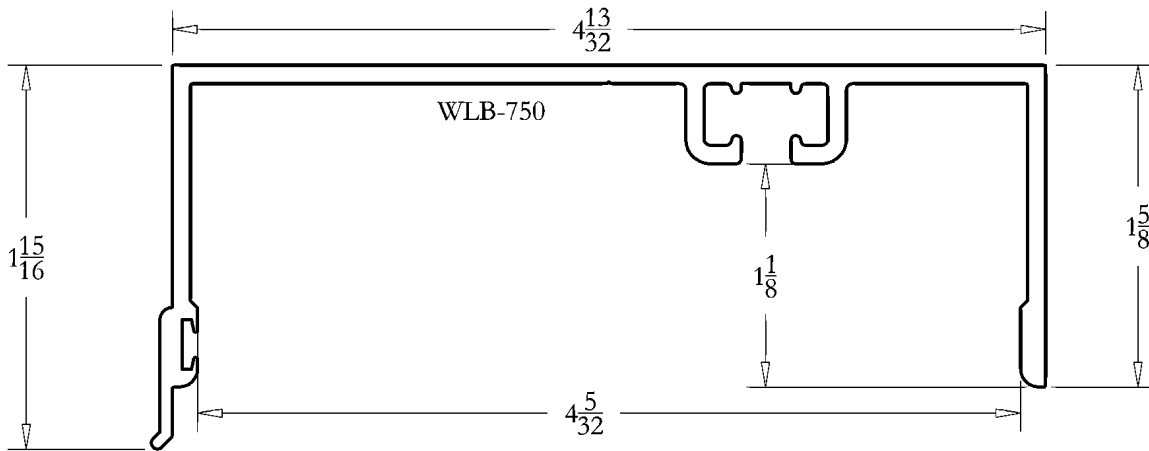
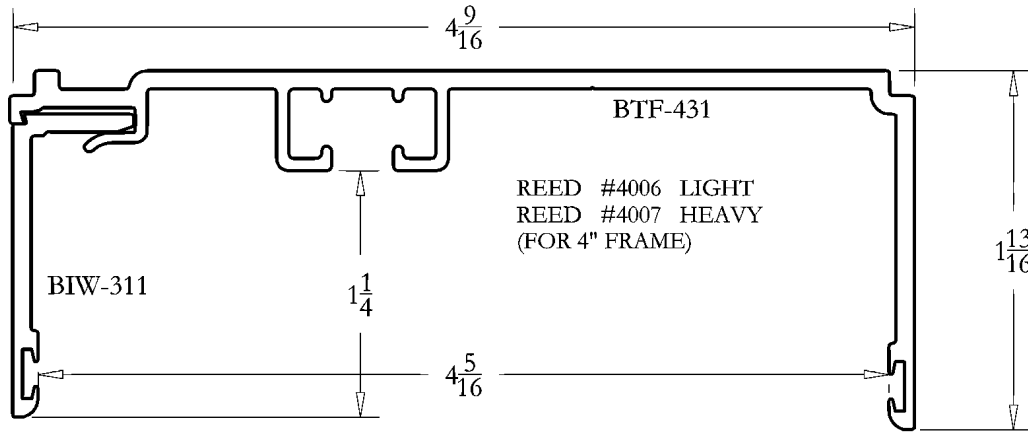

FULL SIZE DETAILS

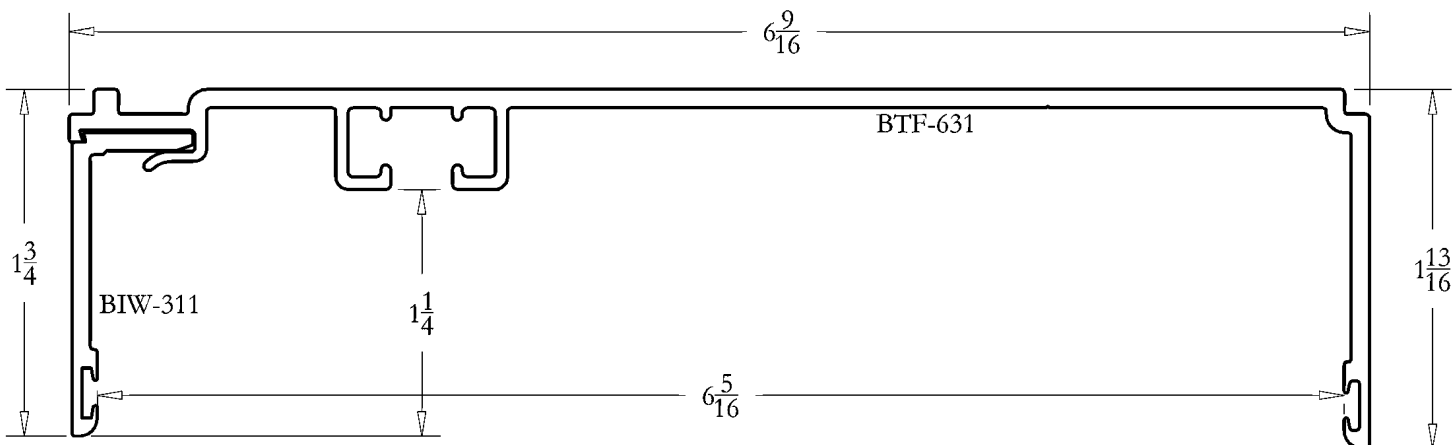
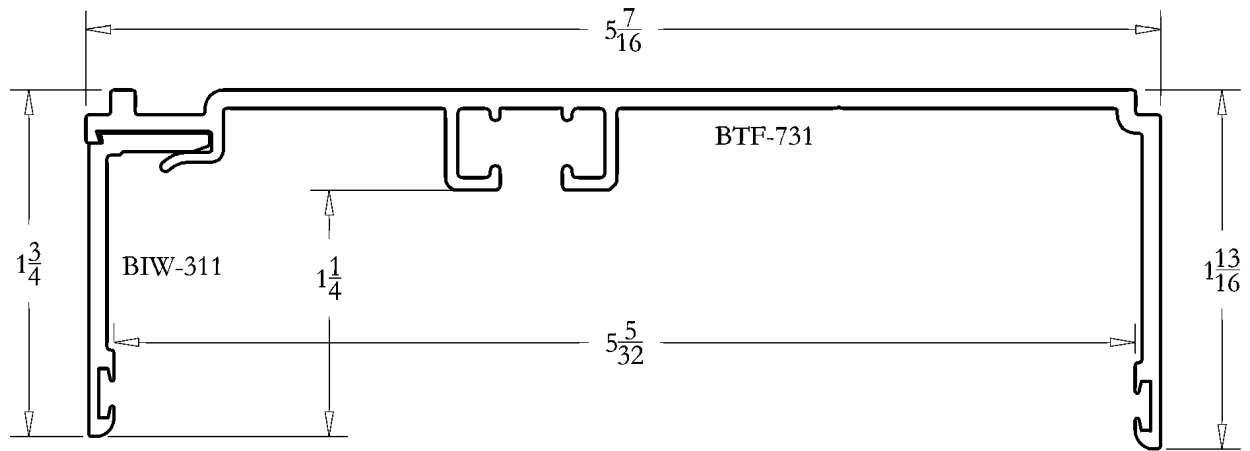
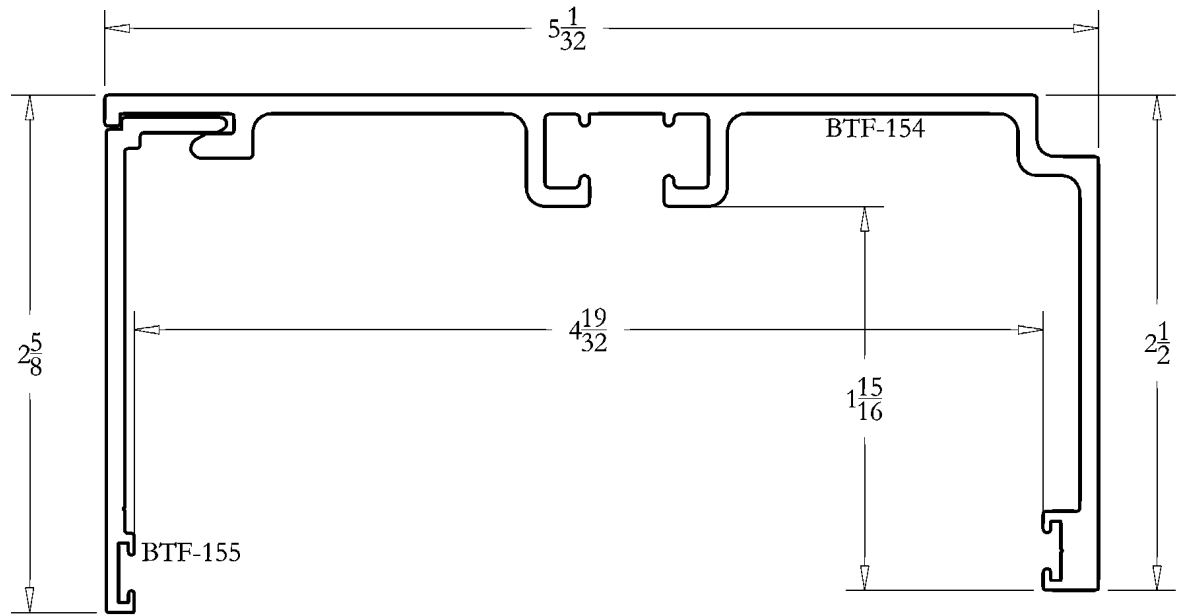

# DETAIL SHEET RECEPTORS AND FLASHING



FULL SIZE DETAILS

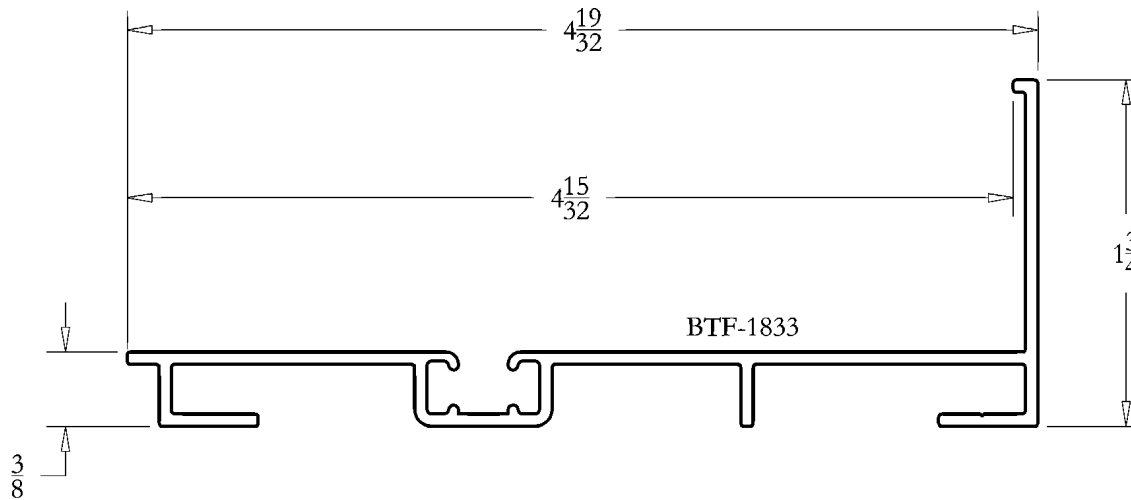
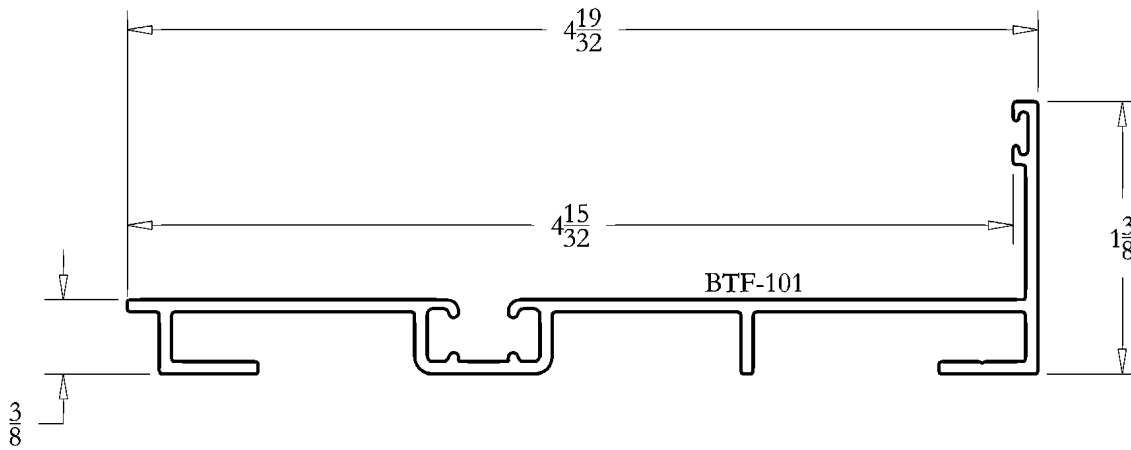
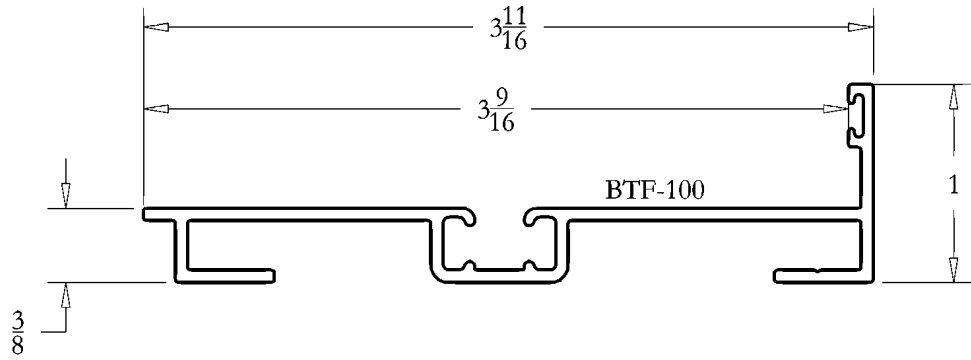

FULL SIZE DETAILS

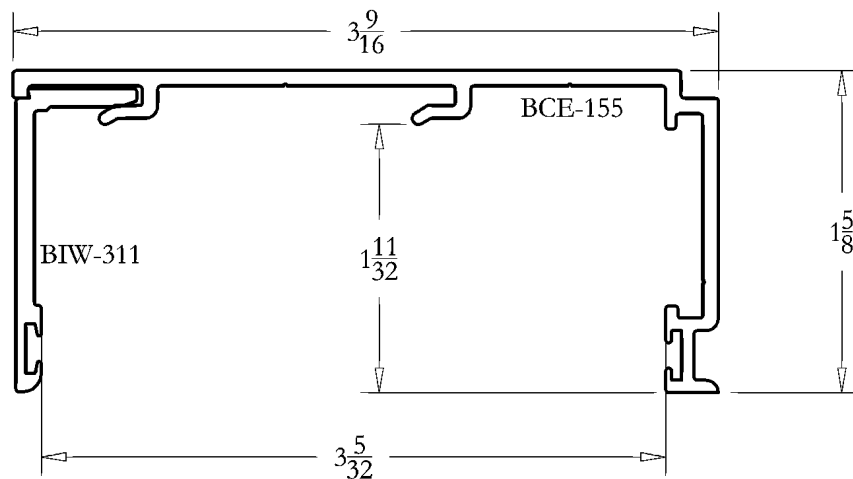
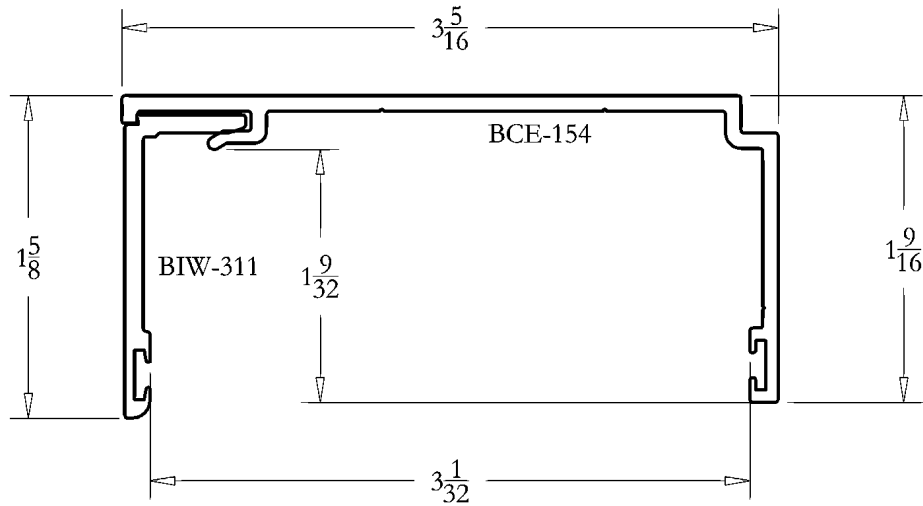
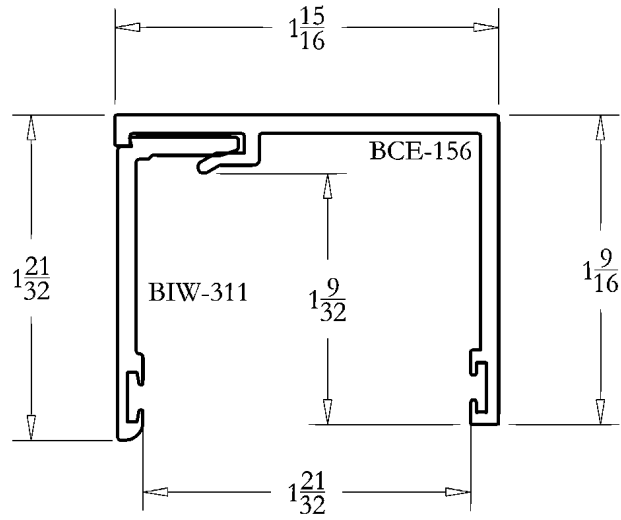

# DETAIL SHEET RECEPTORS AND FLASHING



FULL SIZE DETAILS

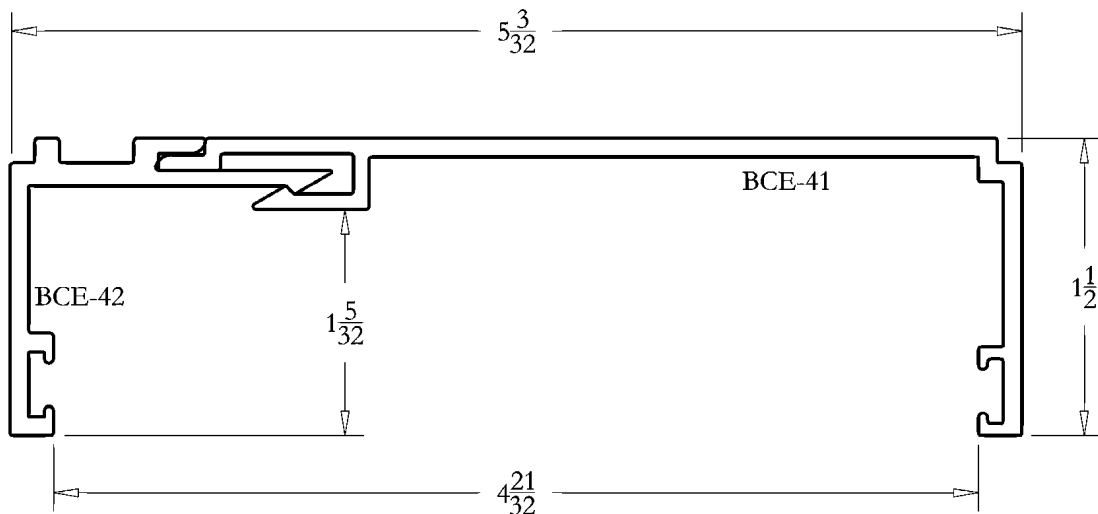
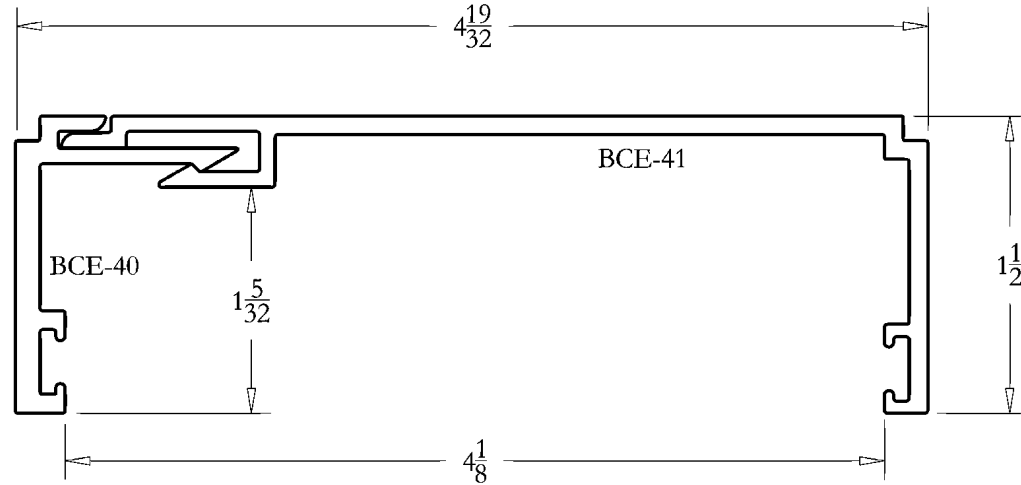
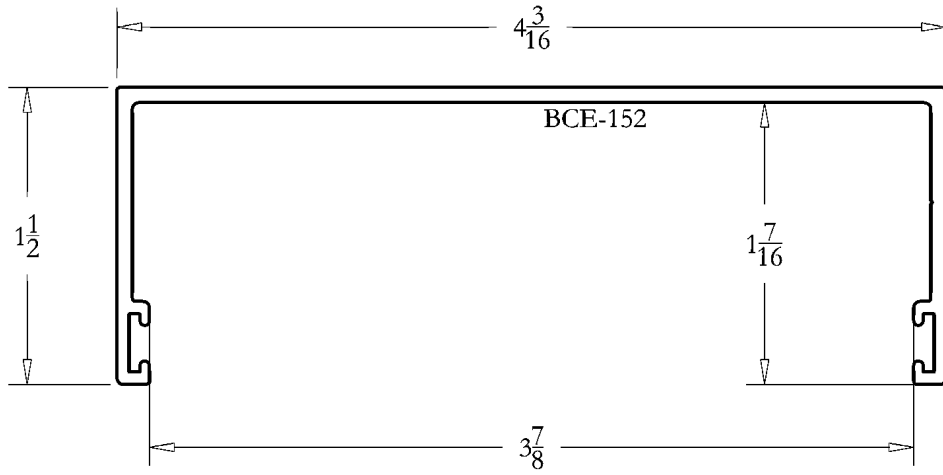

FULL SIZE DETAILS

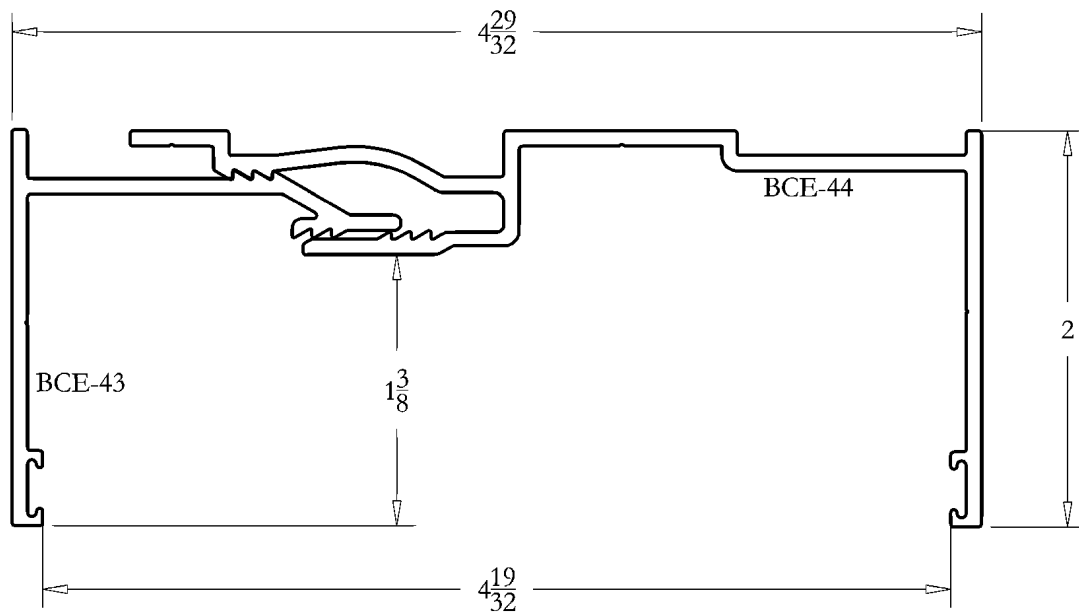
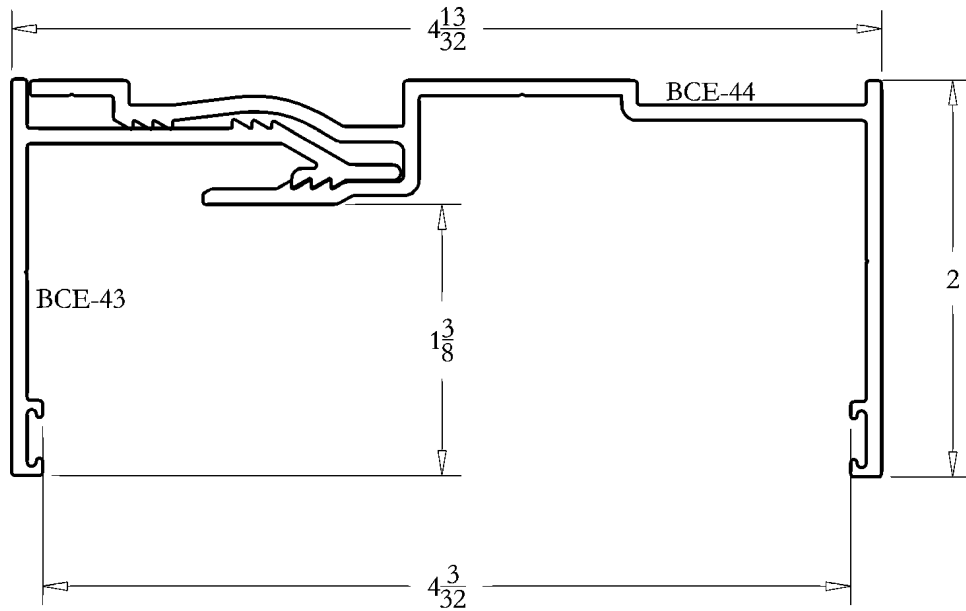

# DETAIL SHEET RECEPTORS AND FLASHING



## FULL SIZE DETAILS

