

1/4 SIZE DETAILS

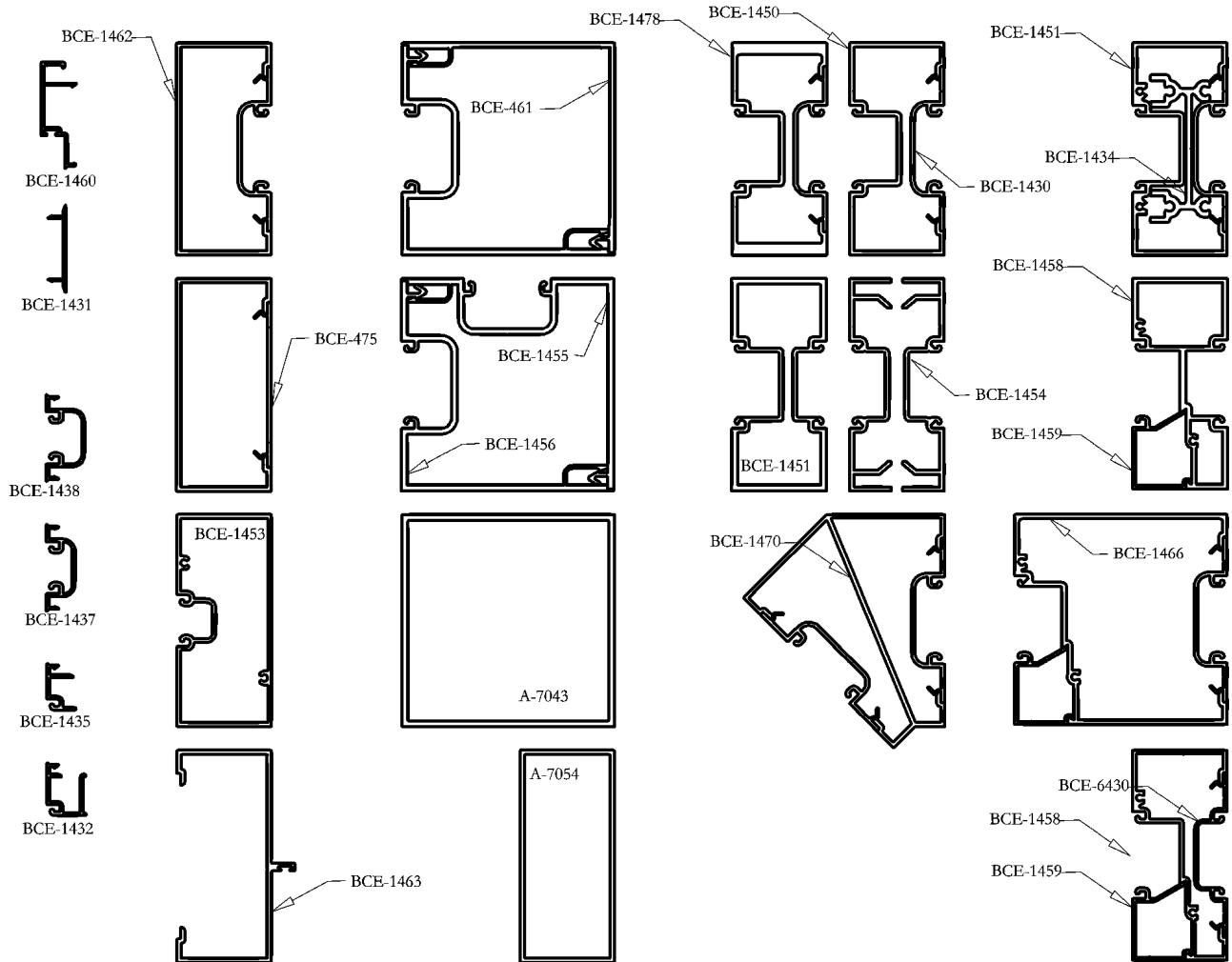

THIS SYSTEM IS DESIGNED TO BE ASSEMBLED WITH #8 SCREWS

UNIVERSAL RUBBER CO 800-782-2375	<u>GASKETS</u> #2028 #2090	1" GLASS, INT'R. & EXT'R. 5/8" GLASS IN 1 3/8" POCKET
REED RUBBER PRODUCTS 800-325-9698	#3734 #4893	GLAZING GASKET INT'R & EXT'R ALTERNATIVE
TREMCO 800-321-6357	TR-2062E	GLAZING GASKET INT'R & EXT'R

DOOR PILE

SCHLEGEL CORP. 800-828-6237	AS SELECTED	USED WITH BCE-1460 AND LIKE SHAPES
AMESBURY GROUP INC. 704-878-6892	AS SELECTED	USED WITH BCE-1460 AND LIKE SHAPES





THIS SYSTEM IS DESIGNED TO BE ASSEMBLED WITH #8 SCREWS.

NO TEST DATA AVAILABLE  
TREDEGAR EXTRUSIONS INC. DOES NOT MAKE ANY WARRANTY EXPRESS OR IMPLIED INCLUDING  
NO WARRANTY OF MERCHANTABILITY OR FITNESS FOR A PARTICULAR PURPOSE AND RESERVES  
THE RIGHT TO MAKE CHANGES  
REPRODUCTION RIGHTS RESERVED

PRICING FACTORS  
2" X 4 1/2" FLUSH GLAZED  
BCE-1450 SERIES

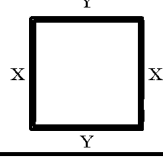
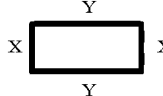
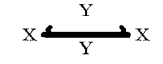

WEIGHT PER FT	EST PER	FACTOR	CAVITY AREA	PART NUMBER	STRUCTURAL VALUES			1/8 SIZE DETAILS
					X-X	Y-Y		
1.326	24.351	18	N/A	BCE1450	0.474	I	2.922	
					0.389	S	1.299	
1.440	25.231	18	N/A	BCE1451	0.517	I	3.088	
					0.414	S	1.372	
1.835	26.884	15	N/A	BCE1455	2.576	I	3.239	
					0.805	S	1.073	
1.838	26.978	15	N/A	BCE1456	3.220	I	2.626	
					1.070	S	0.819	
1.025	21.020	21	N/A	BCE1457	0.345	I	2.086	
					0.342	S	0.825	
0.325	8.543	26	N/A	BCE1459	0.039	I	0.100	
					0.047	S	0.110	
0.308	8.644	28	N/A	BCE1460	0.013	I	0.120	
					0.027	S	0.096	
1.267	21.440	17	N/A	BCE461	2.454	I	2.503	
					0.770	S	0.792	
1.055	19.611	19	N/A	BCE1462	0.513	I	2.796	
					0.399	S	1.243	
0.552	12.246	22	N/A	BCE1430	0.030	I	0.473	
					0.080	S	0.270	
0.163	4.938	30	N/A	BCE1431	0.001	I	0.040	
					0.003	S	0.043	
0.254	6.731	27	N/A	BCE1432	0.018	I	0.026	
					0.037	S	0.039	
1.116	14.838	13	N/A	BCE1434	0.097	I	1.105	
					0.146	S	0.707	
0.184	4.838	26	N/A	BCE1435	0.004	I	0.016	
					0.010	S	0.029	

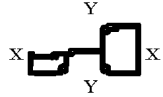
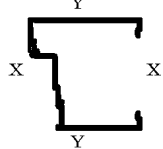
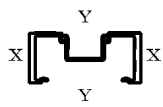
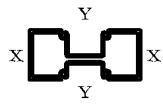
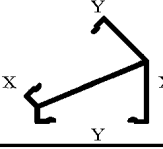
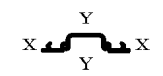
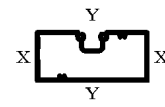
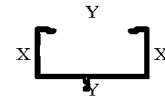
WEIGHT PER FT	EST PER	FACTOR	CAVITY AREA	PART NUMBER	STRUCTURAL VALUES			1/8 SIZE DETAILS
					X-X	I	Y-Y	
0.310	8.030	26	N/A	BCE1437	0.010	I	0.073	
					0.032	S	0.080	
0.340	8.900	26	N/A	BCE1438	0.022	I	0.081	
					0.050	S	0.089	
2.626	17.973	13	N/A	A7043	6.984	I	6.984	
					3.104	S	3.104	
1.424	25.193	18	N/A	A7054	0.862	I	3.081	
					0.862	S	1.369	
0.370	8.473	23	N/A	BCE475	0.001	I	0.356	
					0.003	S	0.204	
1.040	19.149	18	N/A	BCE1454	0.075	I	1.978	
					0.152	S	0.879	
1.624	16.247	17	N/A	BCE1458	0.540	I	2.713	
					0.458	S	1.095	
1.756	30.710	17	N/A	BCE1466	4.676	I	3.099	
					1.917	S	1.216	
2.086	23.440	11	N/A	BCE1478	0.677	I	5.532	
					0.593	S	2.459	
2.138	17.989	15	N/A	BCE1469	0.881	I	4.177	
					0.863	S	1.856	
1.424	27.580	19	N/A	BCE1470	1.619	I	3.345	
					0.625	S	1.143	
0.425	11.493	27	N/A	BCE6430	0.021	I	0.366	
					0.053	S	0.209	
1.489	15.422	20	N/A	BCE1453	0.788	I	2.917	
					0.761	S	1.296	
1.124	20.894	19	N/A	BCE1463	0.564	I	2.801	
					0.420	S	1.237	

WINDLOAD CHARTS  
2" X 4 1/2" FLUSH GLAZED  
BCE-1450 SERIES

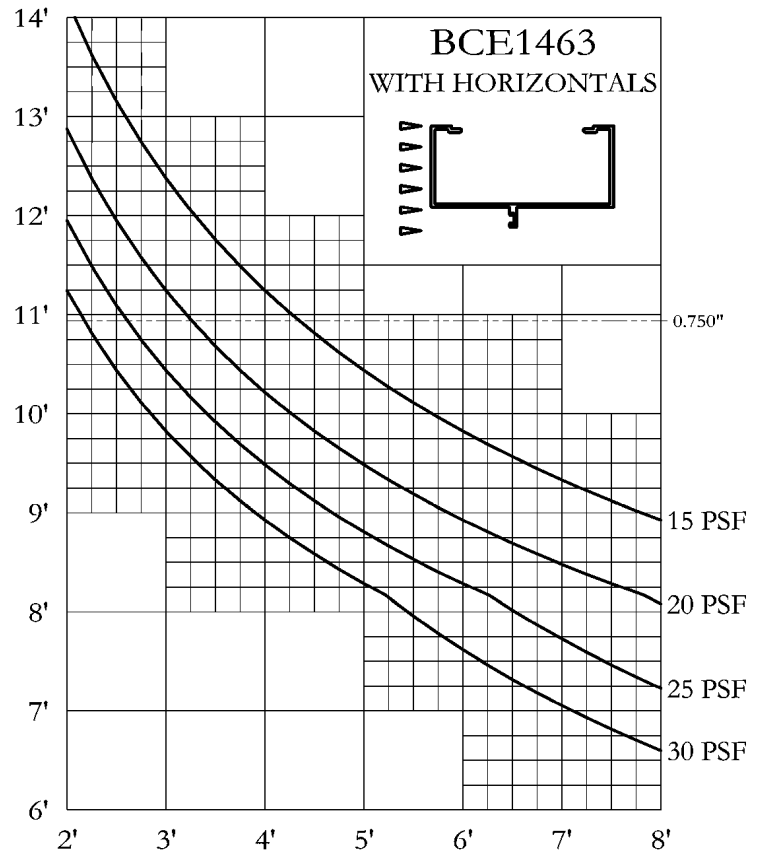
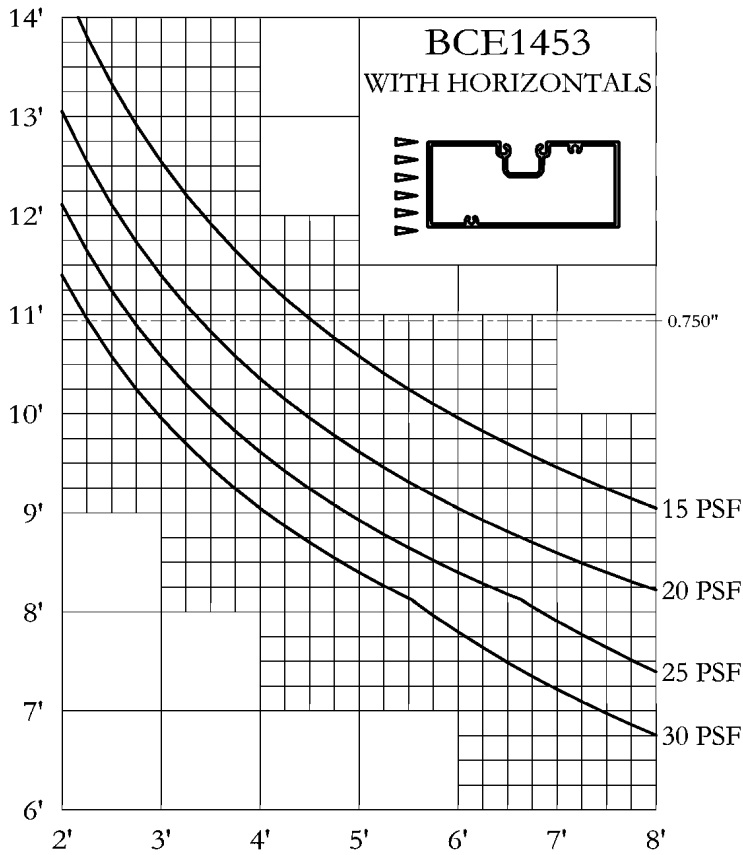
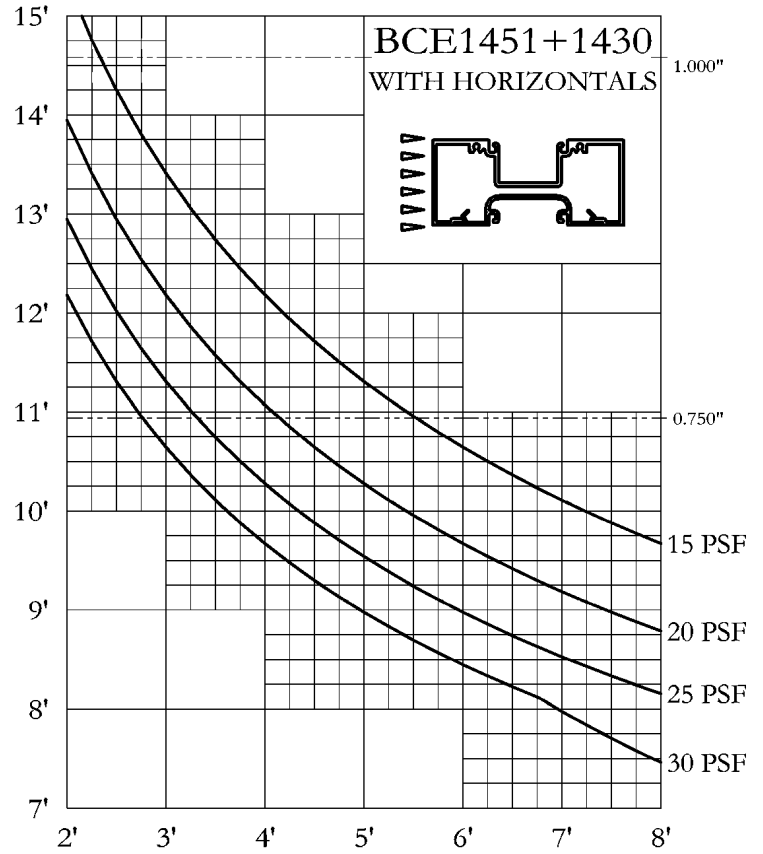
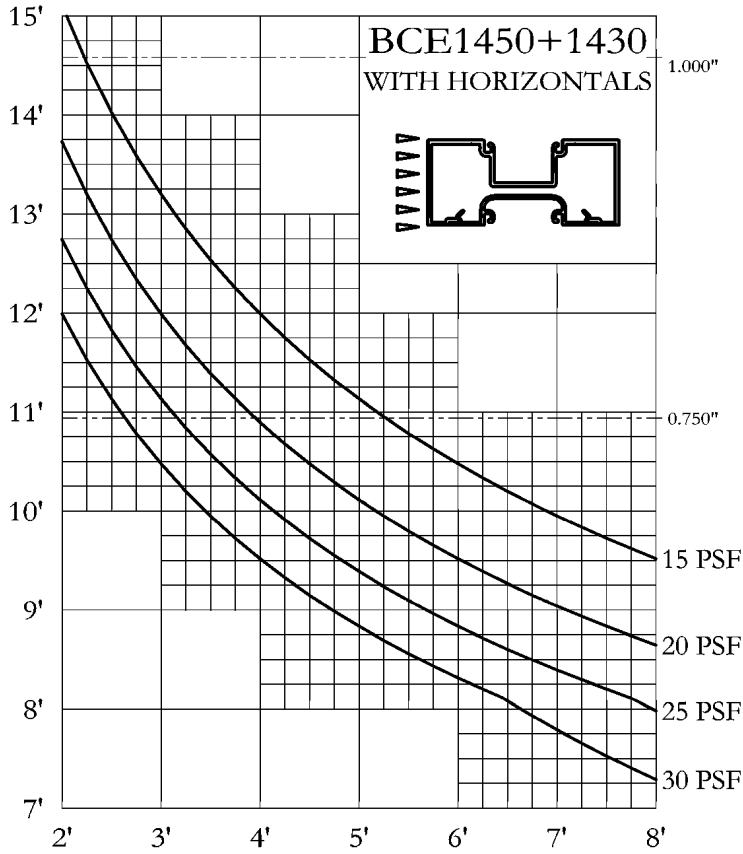

#1 THESE WINDLOAD CHARTS ARE BASED UPON THE LESSER OF DEFLECTION RATIO ( $L/175$ ) OR STRESS (12667)

#2 THESE STRUCTURAL CURVES ARE ESTIMATES AND ARE PRESENTED TO THE BEST KNOWLEDGE OF THE WILLIAM L BONNELL CO. IT IS, HOWEVER, THE RESPONSIBILITY OF THE CUSTOMER TO BE SATISFIED THAT THE CURVES ARE CORRECT. THE WILLIAM L BONNELL CO. MAY NOT BE HELD RESPONSIBLE IN ANY WAY FOR THE FAILURE OF PERFORMANCE RESULTING FROM THE USE OF THESE CURVES.

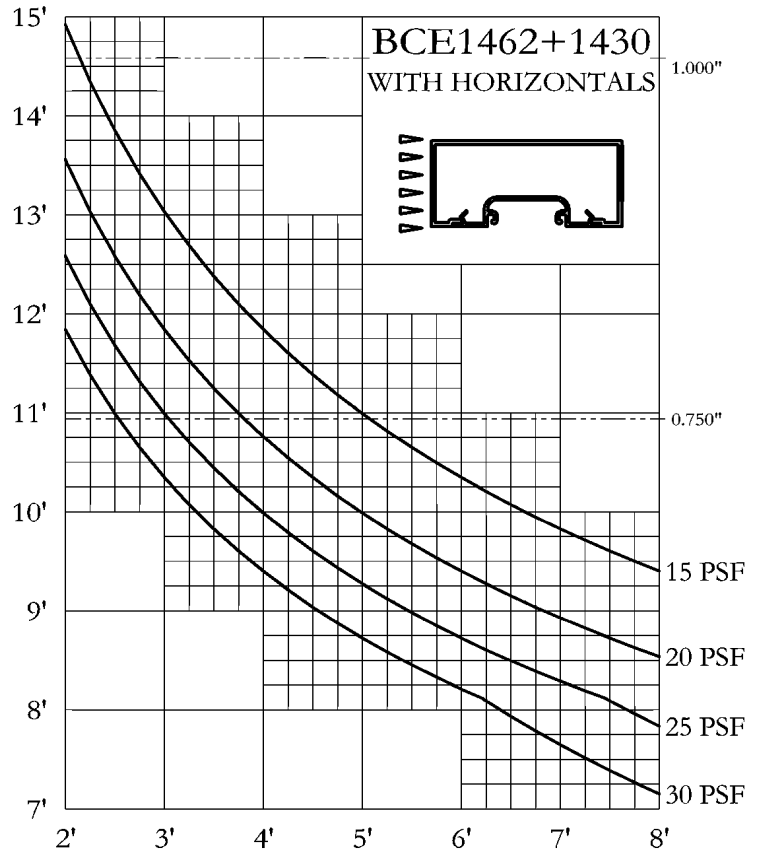
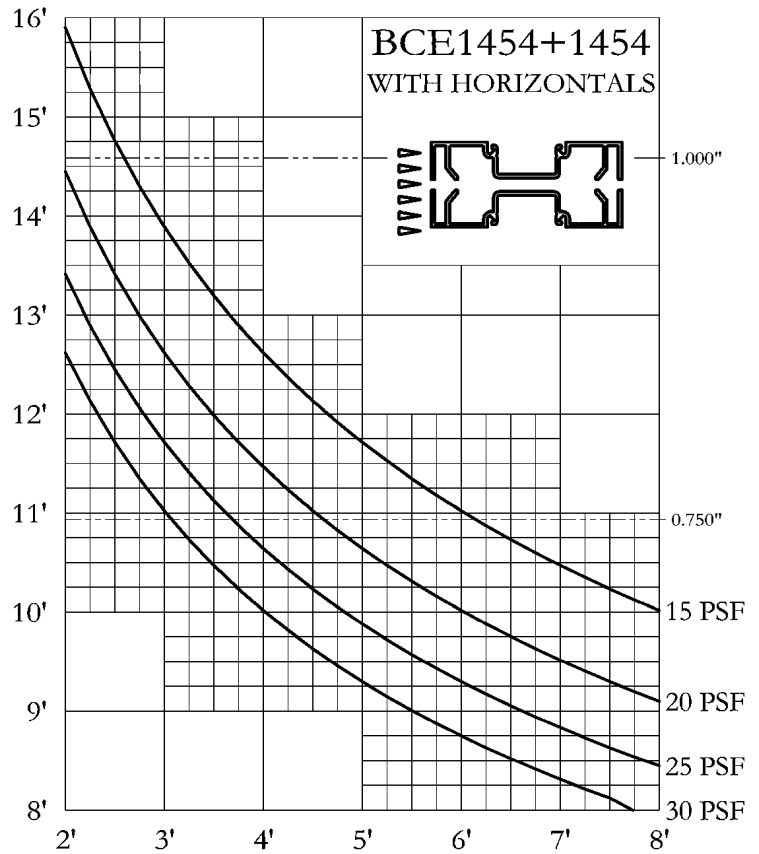
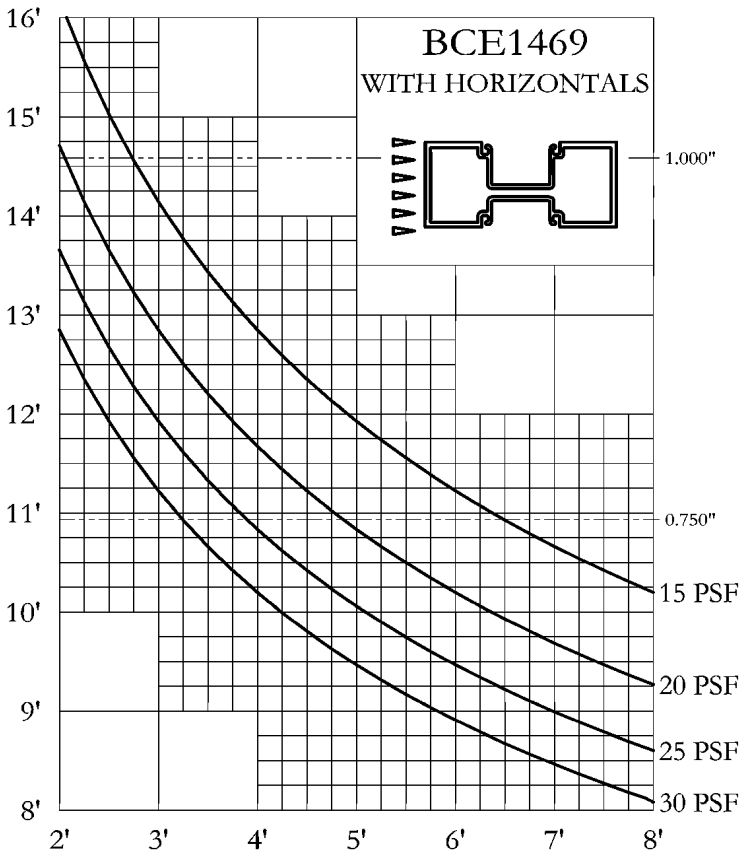

#1 THESE WINDLOAD CHARTS ARE BASED UPON THE LESSER OF DEFLECTION RATIO ( $L/175$ ) OR STRESS (12667)

#2 THESE STRUCTURAL CURVES ARE ESTIMATES AND ARE PRESENTED TO THE BEST KNOWLEDGE OF THE WILLIAM L BONNELL CO. IT IS, HOWEVER, THE RESPONSIBILITY OF THE CUSTOMER TO BE SATISFIED THAT THE CURVES ARE CORRECT. THE WILLIAM L BONNELL CO. MAY NOT BE HELD RESPONSIBLE IN ANY WAY FOR THE FAILURE OF PERFORMANCE RESULTING FROM THE USE OF THESE CURVES.

WINDLOAD CHARTS  
2" X 4 1/2" FLUSH GLAZED  
BCE-1450 SERIES

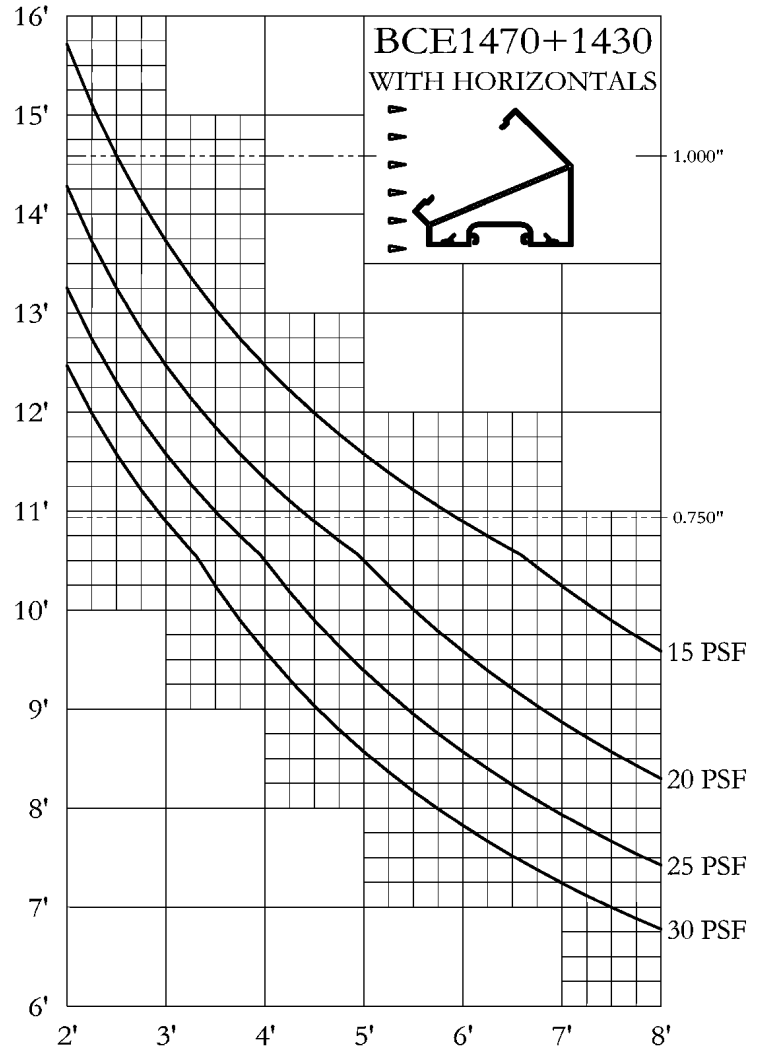
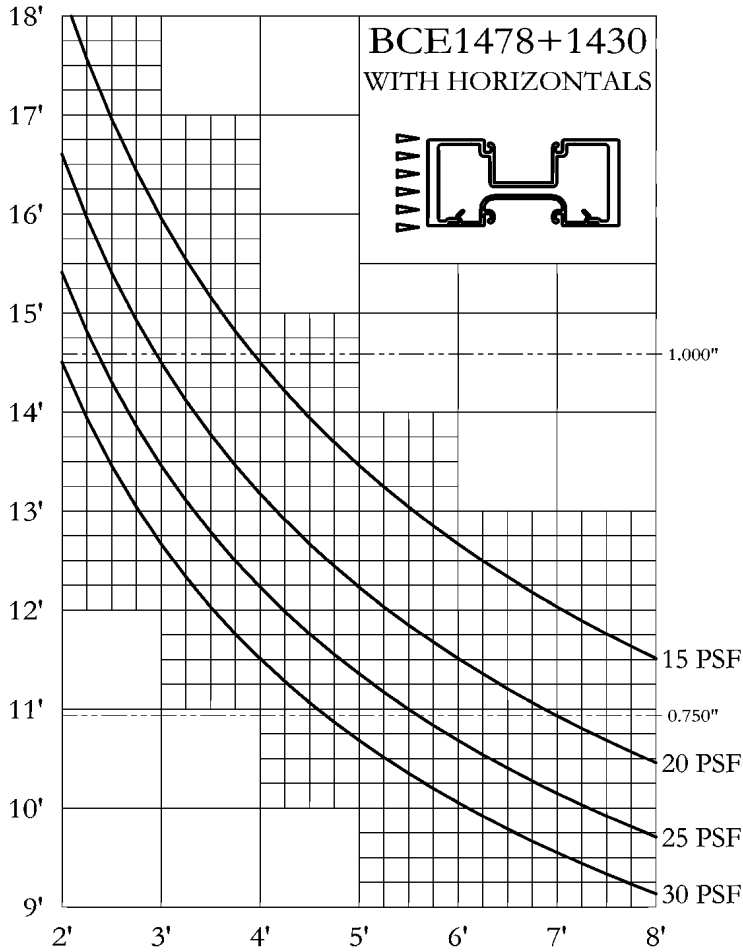

#1 THESE WINDLOAD CHARTS ARE BASED UPON THE LESSER OF DEFLECTION RATIO (L/175) OR STRESS (12667)

#2 THESE STRUCTURAL CURVES ARE ESTIMATES AND ARE PRESENTED TO THE BEST KNOWLEDGE OF THE WILLIAM L BONNELL CO. IT IS, HOWEVER, THE RESPONSIBILITY OF THE CUSTOMER TO BE SATISFIED THAT THE CURVES ARE CORRECT. THE WILLIAM L BONNELL CO. MAY NOT BE HELD RESPONSIBLE IN ANY WAY FOR THE FAILURE OF PERFORMANCE RESULTING FROM THE USE OF THESE CURVES.

FULL SIZE DETAILS

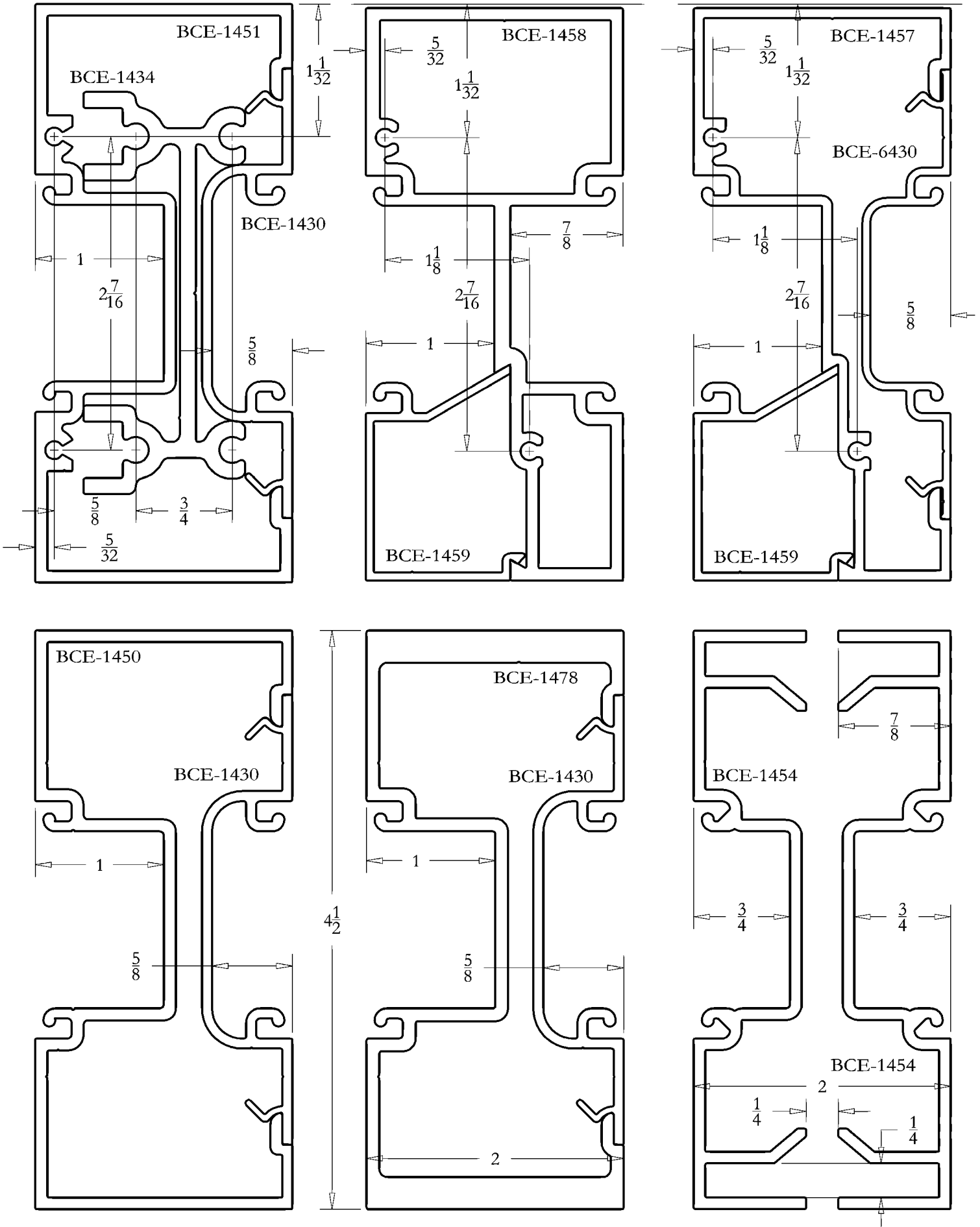

DETAIL SHEET  
2" X 4 1/2" FLUSH GLAZING  
BCE-1450



FULL SIZE DETAILS

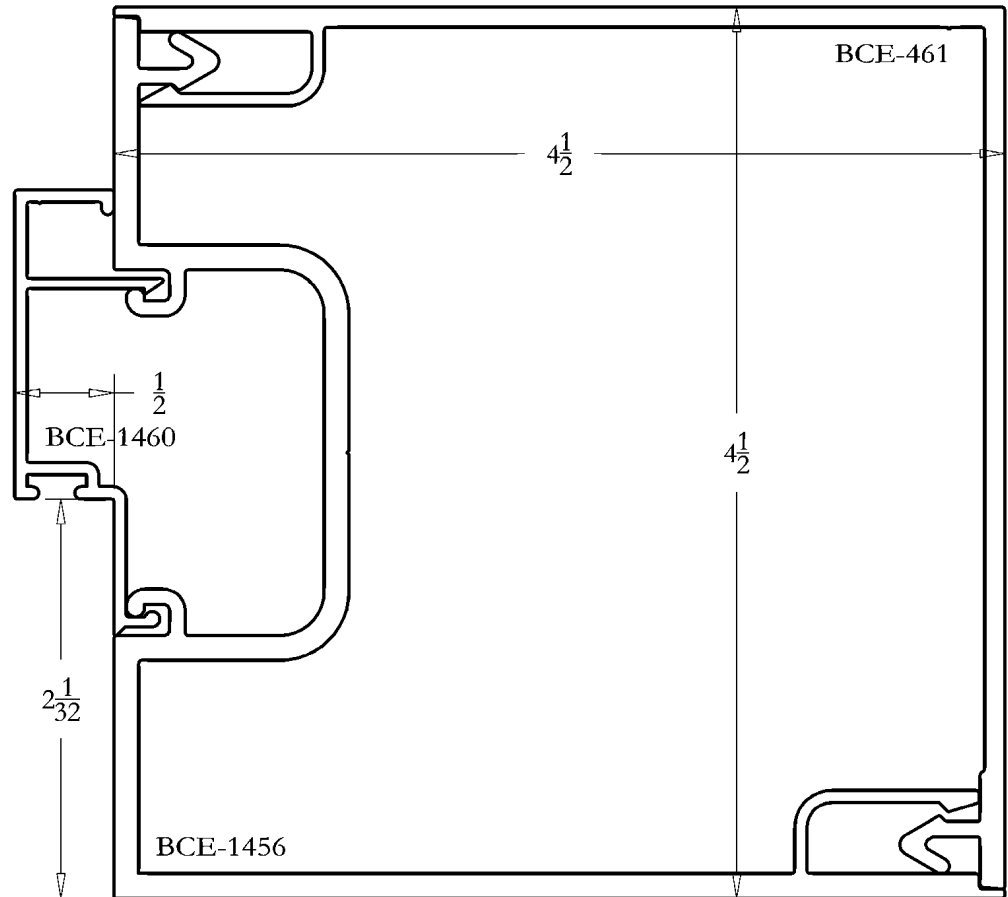
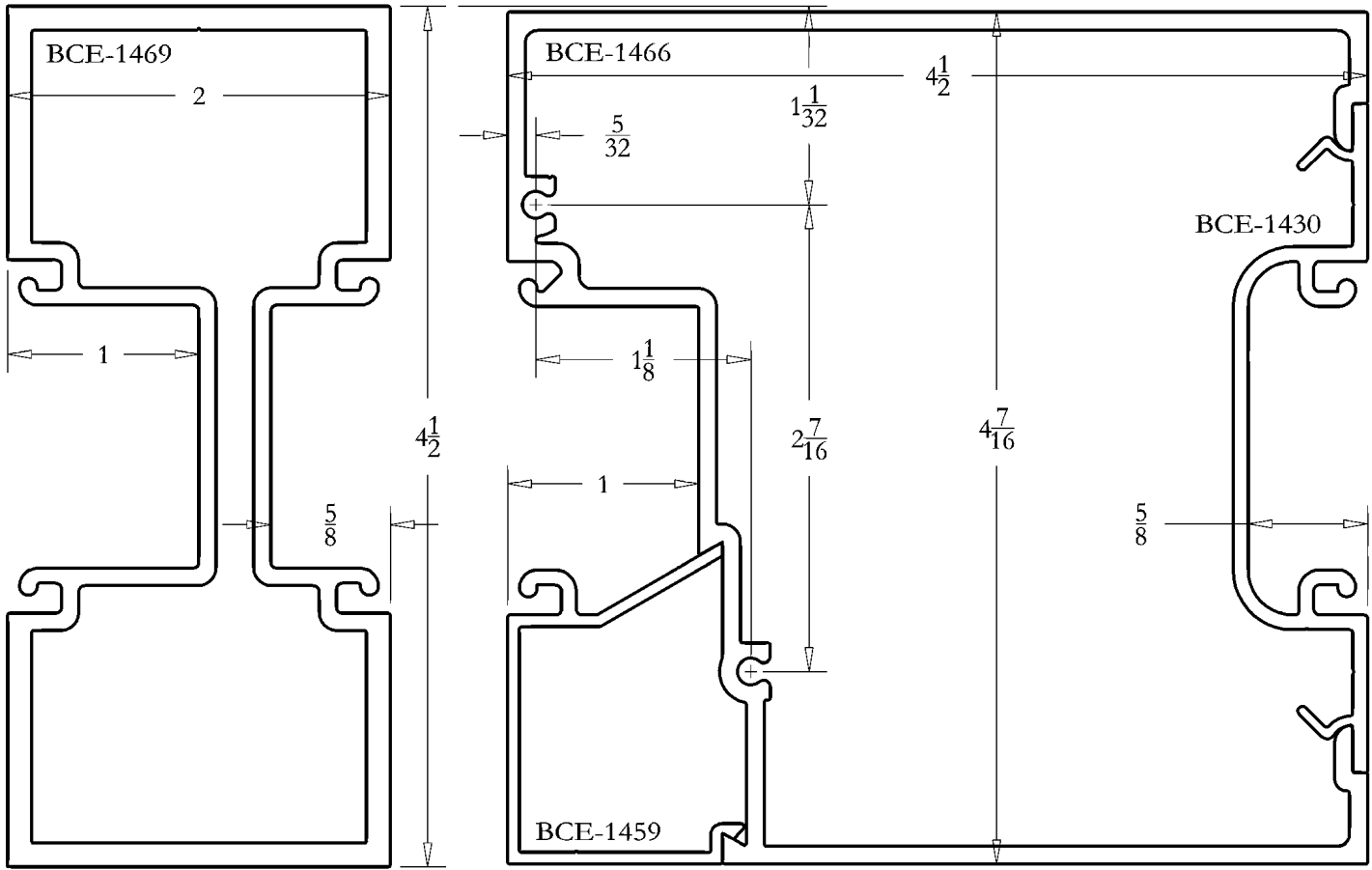

FULL SIZE DETAILS

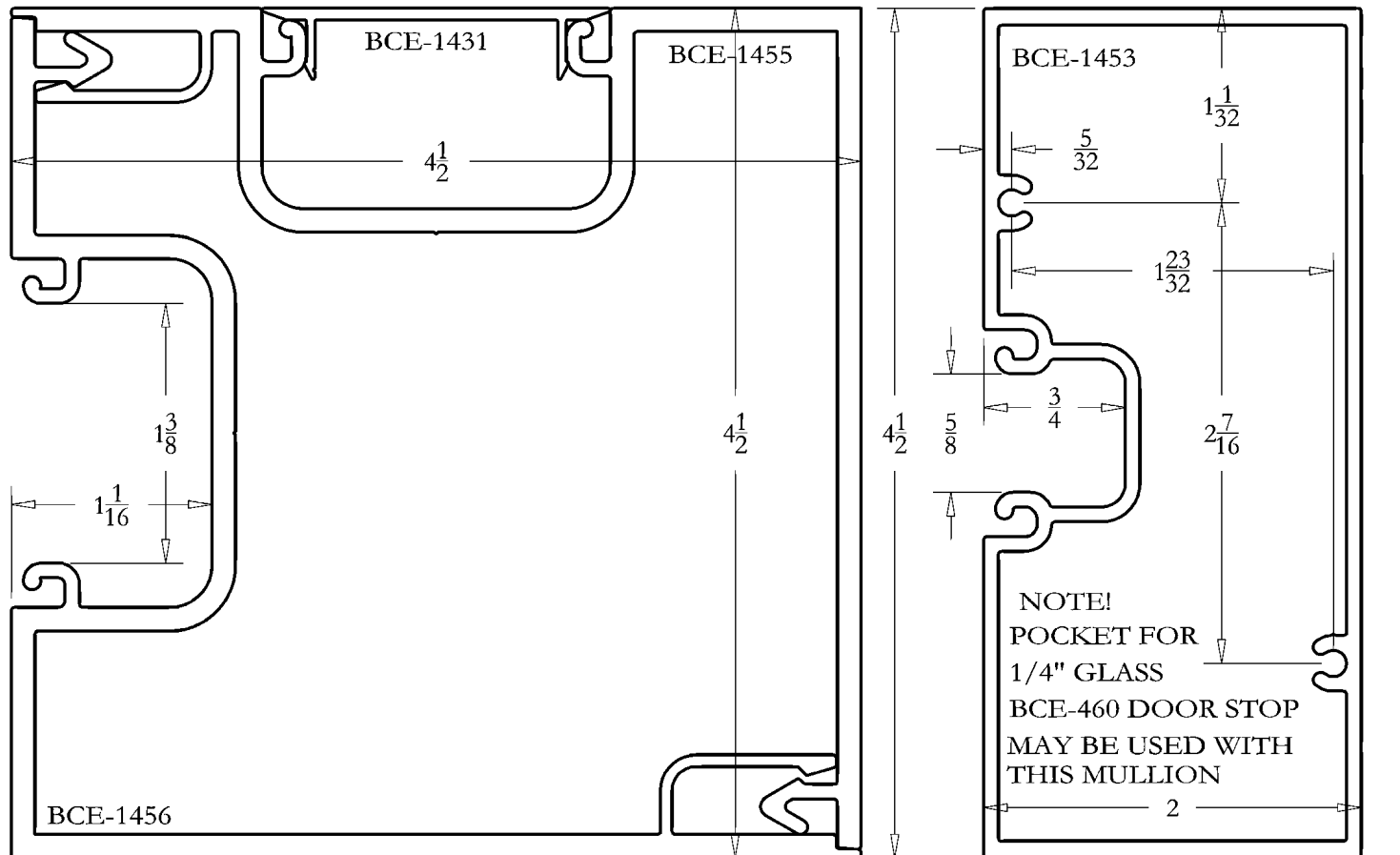
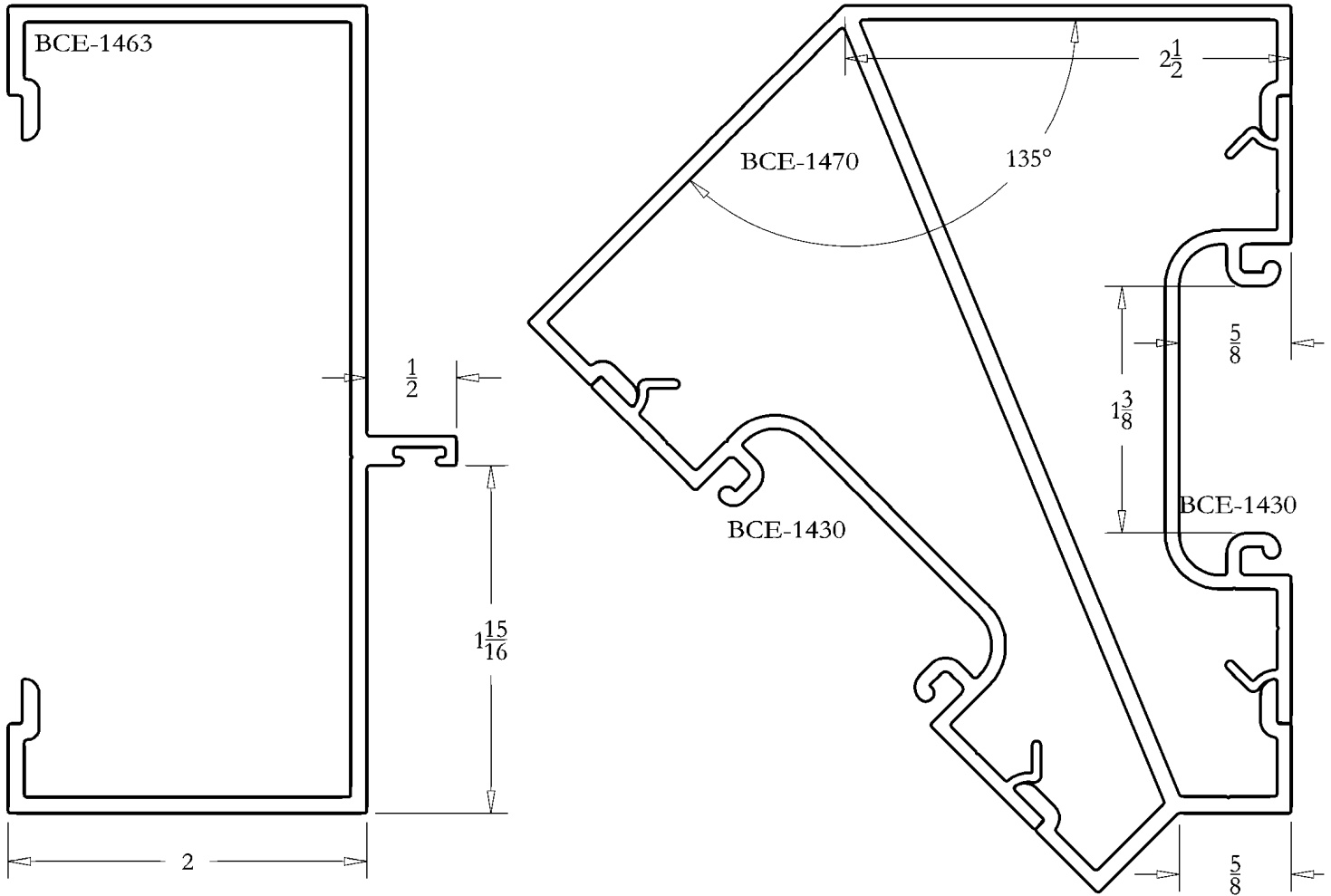

DETAIL SHEET  
2" X 4 1/2" FLUSH GLAZING  
BCE-1450



FULL SIZE DETAILS

