

THIS SYSTEM IS DESIGNED TO BE ASSEMBLED WITH #12 SCREWS.

GASKET

REED RUBBER PRODUCTS	#3678	INTERIOR & EXTERIOR GASKETS (LIGHT)
800-325-9698	#3679	INTERIOR & EXTERIOR GASKETS (NORMAL)
	#3680	INTERIOR & EXTERIOR GASKETS (HEAVY)
UNIVERSAL RUBBER CO.		
800-782-2375	#3194	INTERIOR & EXTERIOR GASKETS
TREMCO		
800-321-6357	#TR-2860E	INTERIOR & EXTERIOR GASKETS (NORMAL)

DOOR PILE





SCHLEGEL CORP.	AS SELECTED	USED WITH BCE-1870 AND LIKE SHAPES
800-828-6237		
AMESBURY GROUP INC.	AS SELECTED	USED WITH BCE-1870 AND LIKE SHAPES
704-878-6892		

NO TEST DATA AVAILABLE
TREDEGAR EXTRUSIONS INC. DOES NOT MAKE ANY WARRANTY EXPRESS OR IMPLIED INCLUDING
NO WARRANTY OF MERCHANTABILITY OR FITNESS FOR A PARTICULAR PURPOSE AND RESERVES
THE RIGHT TO MAKE CHANGES
REPRODUCTION RIGHTS RESERVED

PRICING FACTORS
2 X 4 1/2 FLUSH GLAZED
BCE-1850 SERIES

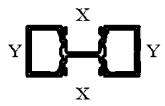
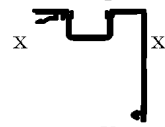
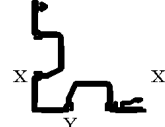
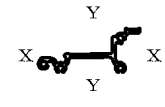
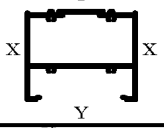
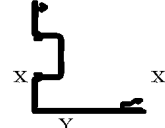
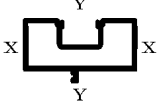

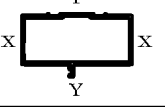
WEIGHT PER FT	EST PER	FACTOR	CAVITY AREA	PART NUMBER	STRUCTURAL VALUES			1/8 SIZE DETAILS
					X-X	Y-Y		
1.260	17.592	14	N/A	BCE1848	0.275	I	1.379	
					0.297	S	0.690	
0.280	6.808	24	N/A	BCE1849	0.001	I	0.119	
					0.003	S	0.095	
1.104	20.896	19	N/A	BCE1850	0.363	I	2.261	
					0.363	S	0.888	
1.588	15.914	19	N/A	BCE1851	0.524	I	2.604	
					0.432	S	1.063	
1.187	24.008	20	N/A	BCE1852	0.417	I	2.861	
					0.350	S	1.272	
0.284	9.065	32	N/A	BCE1853	0.040	I	0.074	
					0.052	S	0.091	
0.442	11.782	27	N/A	BCE1854	0.019	I	0.428	
					0.055	S	0.238	
1.690	32.345	19	N/A	BCE1855	0.788	I	3.146	
					0.712	S	1.398	
1.596	16.070	19	N/A	BCE1856	0.738	I	3.198	
					0.710	S	1.421	
1.289	25.425	20	N/A	BCE1857	0.451	I	2.993	
					0.364	S	1.330	
1.628	18.167	20	N/A	BCE1858	0.657	I	3.041	
					0.634	S	1.352	
0.946	20.268	21	N/A	BCE1859	0.209	I	2.152	
					0.167	S	0.956	
1.033	21.620	21	N/A	BCE1860	0.133	I	2.087	
					0.204	S	0.928	
0.125	4.082	33	N/A	BCE1863	0.000	I	0.033	
					0.000	S	0.036	

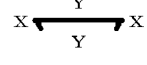
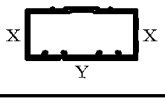
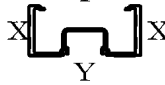
WEIGHT PER FT	EST PER	FACTOR	CAVITY AREA	PART NUMBER	STRUCTURAL VALUES			1/8 SIZE DETAILS
					X-X	I	Y-Y	
2.303	30.399	13	N/A	BCE1861	4.313	I	0.889	
					1.917	S	0.879	
1.542	26.550	17	N/A	BCE1864	2.358	I	2.807	
					0.741	S	0.934	
1.776	30.813	17	N/A	BCE1865	2.708	I	2.710	
					0.894	S	0.896	
1.142	15.885	14	N/A	BCE1866	0.213	I	1.393	
					0.203	S	0.636	
2.250	24.281	17	N/A	BCE1867	2.547	I	5.298	
					1.220	S	2.382	
1.523	26.082	17	N/A	BCE1868	2.783	I	2.320	
					0.928	S	0.726	
1.675	17.553	19	N/A	BCE1869	0.832	I	3.200	
					0.593	S	1.417	
0.211	6.885	33	N/A	BCE1870	0.009	I	0.064	
					0.020	S	0.057	
1.754	15.070	15	N/A	BCE1871	1.149	I	3.346	
					0.784	S	1.482	
0.104	3.230	31	N/A	BCE1872	0.001	I	0.002	
					0.004	S	0.006	
0.126	3.999	32	N/A	BCE1873	0.002	I	0.010	
					0.007	S	0.020	
0.328	8.836	27	N/A	BCE1876	0.002	I	0.366	
					0.006	S	0.204	
1.824	13.915	15	N/A	BCE1877	1.129	I	3.500	
					1.045	S	1.566	
1.760	23.036	13	N/A	BCE1878	0.578	I	4.774	
					0.494	S	2.122	

PRICING FACTORS
2 X 4 1/2 FLUSH GLAZED
BCE-1850 SERIES



WEIGHT PER FT	EST PER	FACTOR	CAVITY AREA	PART NUMBER	STRUCTURAL VALUES			1/8 SIZE DETAILS
					X-X		Y-Y	
0.413	11.903	29	N/A	BCE1879	0.054	I	0.240	
					0.096	S	0.202	
0.109	2.712	25	N/A	BCE5	0.002	I	0.004	
					0.006	S	0.009	
0.474	12.592	27	N/A	BCE114	0.006	I	1.116	
					0.010	S	0.375	
1.267	21.440	17	N/A	BCE461	2.454	I	2.503	
					0.770	S	0.791	
1.104	14.085	13	N/A	BCE9301	0.027	I	1.849	
					0.048	S	0.875	
0.181	5.808	32	N/A	BCE9370	0.005	I	0.019	
					0.013	S	0.030	
0.394	10.574	27	N/A	BCE9371	0.053	I	0.181	
					0.067	S	0.111	
1.424	12.973	18	N/A	A7054	0.862	I	3.081	
					0.862	S	1.369	
1.967	17.973	18	N/A	A7047	5.308	I	5.308	
					2.359	S	2.359	
2.624	17.973	13	N/A	A7043	6.984	I	6.984	
					3.104	S	3.104	

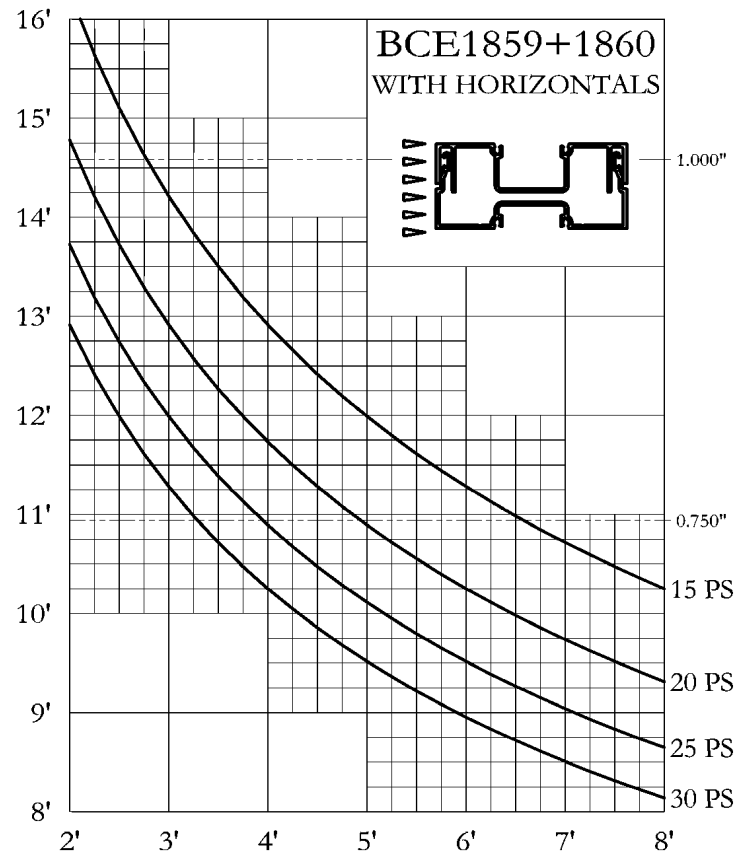
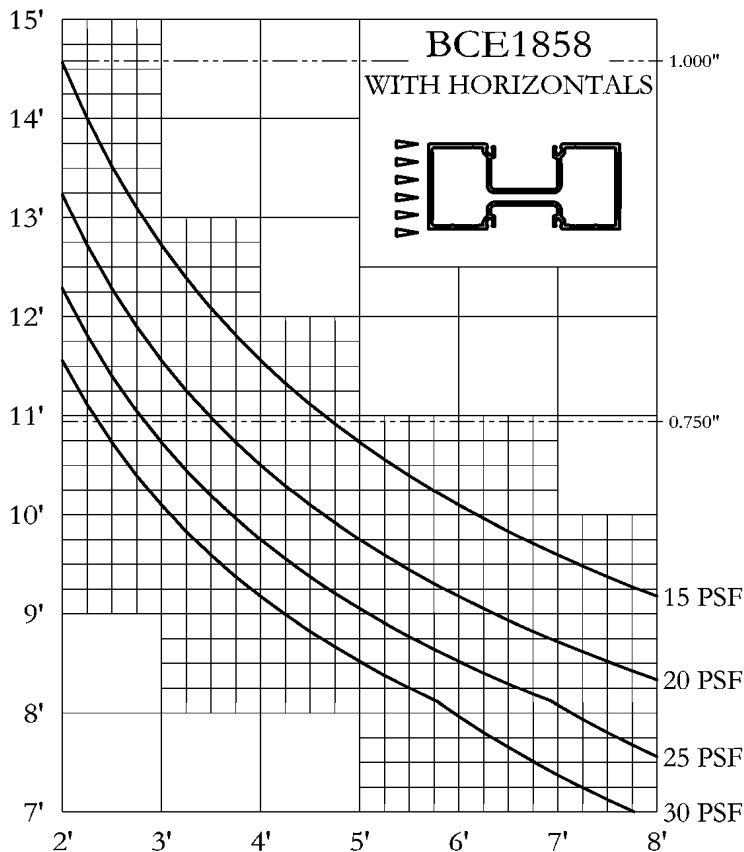
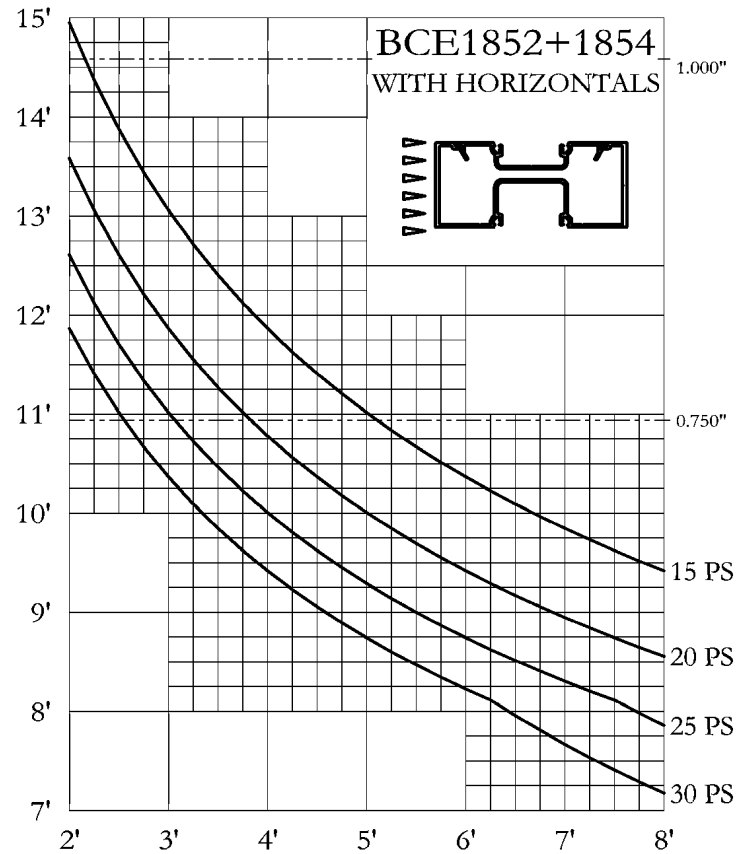
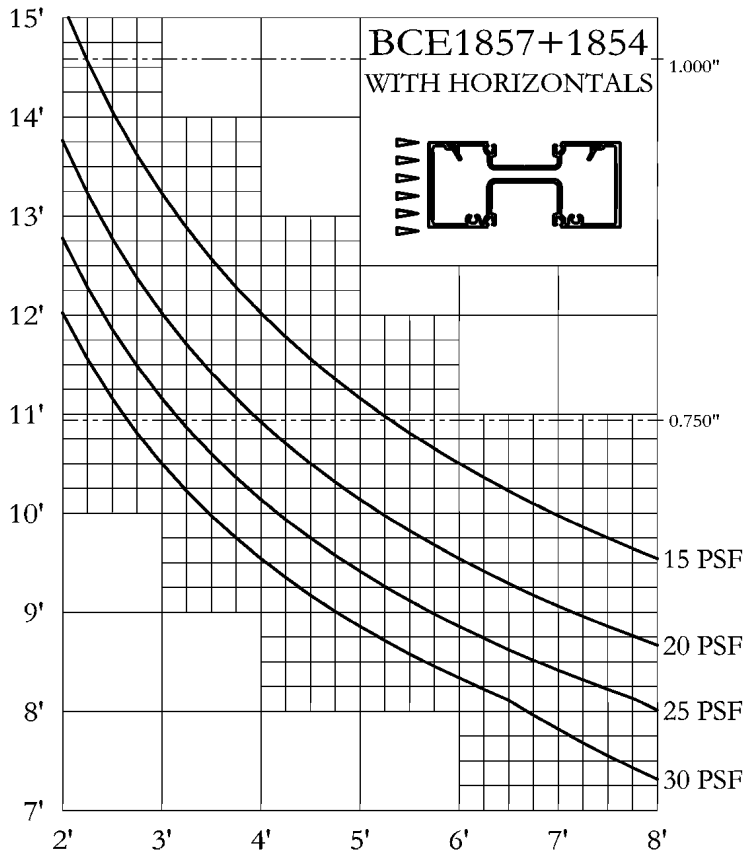

#1 THESE WINDLOAD CHARTS ARE BASED UPON THE LESSER OF DEFLECTION RATIO ($L/175$) OR STRESS (12667)

#2 THESE STRUCTURAL CURVES ARE ESTIMATES AND ARE PRESENTED TO THE BEST KNOWLEDGE OF THE WILLIAM L BONNELL CO. IT IS, HOWEVER, THE RESPONSIBILITY OF THE CUSTOMER TO BE SATISFIED THAT THE CURVES ARE CORRECT. THE WILLIAM L BONNELL CO. MAY NOT BE HELD RESPONSIBLE IN ANY WAY FOR THE FAILURE OF PERFORMANCE RESULTING FROM THE USE OF THESE CURVES.

WINDLOAD CHARTS
2 X 4 1/2 FLUSH GLAZED
BCE-1850 SERIES

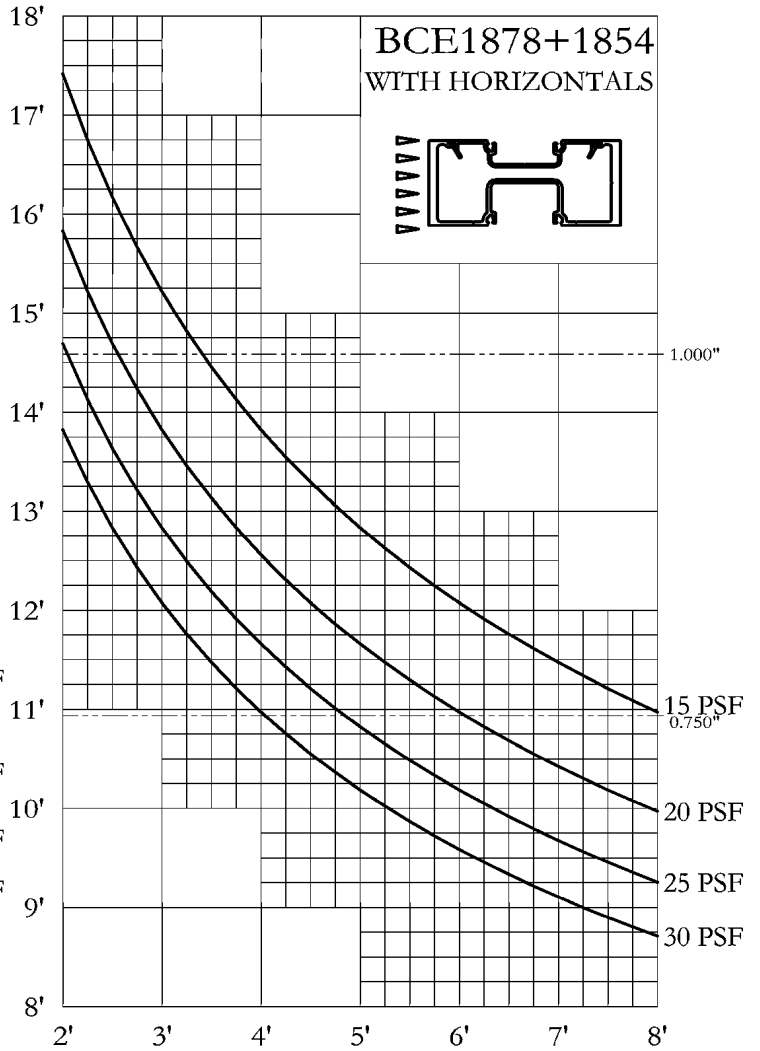
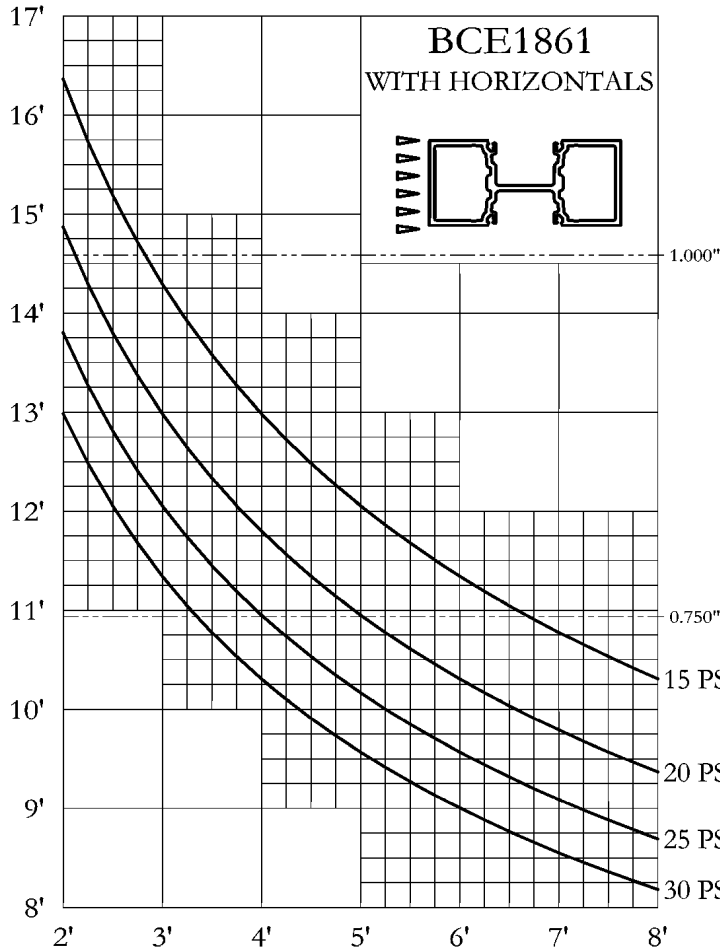

#1 THESE WINDLOAD CHARTS ARE BASED UPON THE LESSER OF DEFLECTION RATIO (L/175) OR STRESS (12667)

#2 THESE STRUCTURAL CURVES ARE ESTIMATES AND ARE PRESENTED TO THE BEST KNOWLEDGE OF THE WILLIAM L BONNELL CO. IT IS, HOWEVER, THE RESPONSIBILITY OF THE CUSTOMER TO BE SATISFIED THAT THE CURVES ARE CORRECT. THE WILLIAM L BONNELL CO. MAY NOT BE HELD RESPONSIBLE IN ANY WAY FOR THE FAILURE OF PERFORMANCE RESULTING FROM THE USE OF THESE CURVES.

FULL SIZE DETAILS

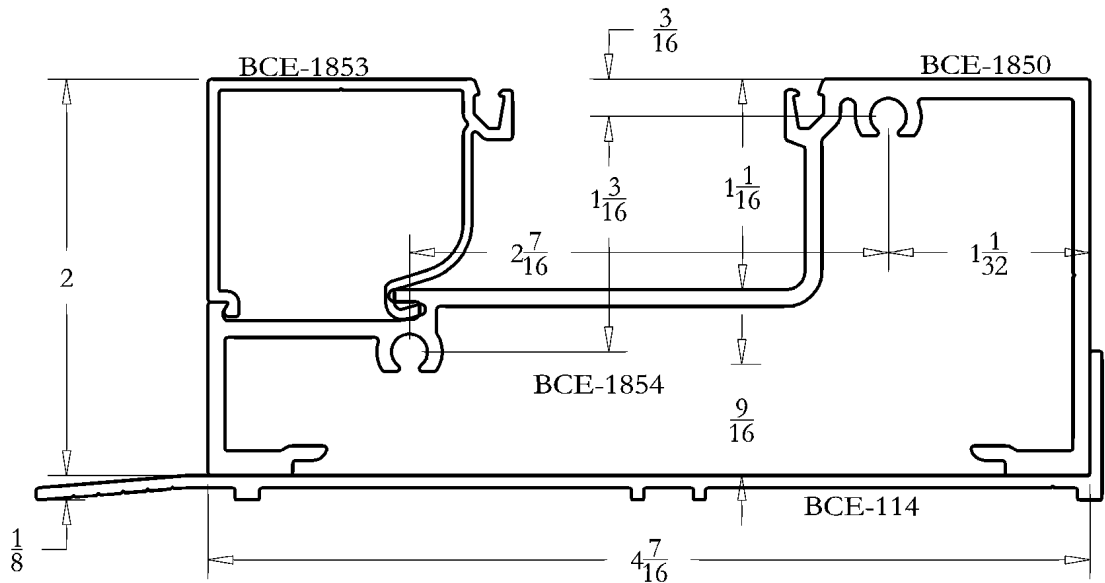
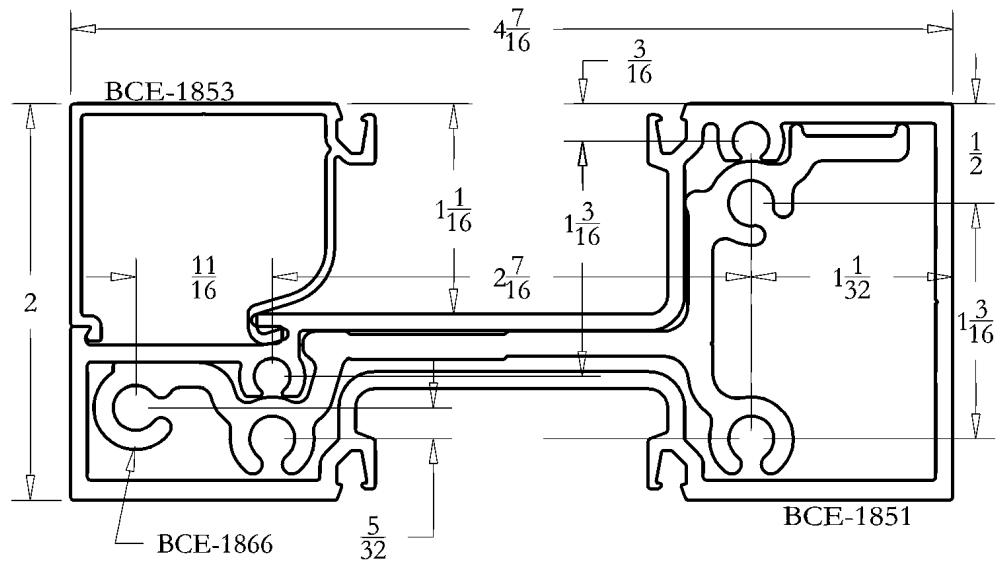
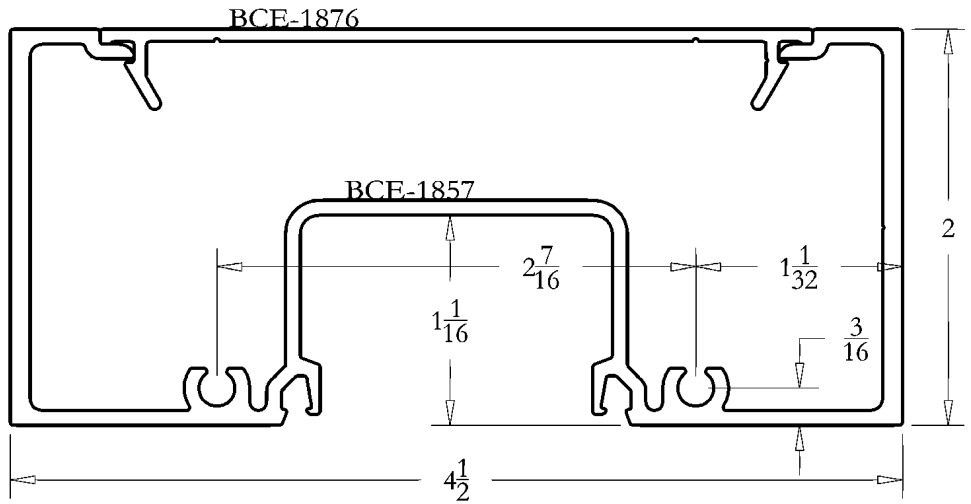
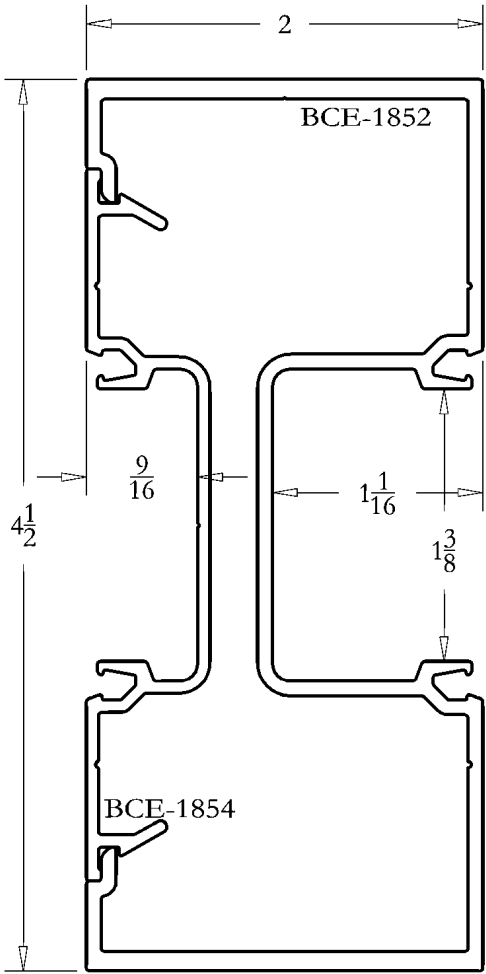

DETAIL SHEET
2" x 4 1/2" FLUSH GLAZED
BCE-1850 SERIES



FULL SIZE DETAILS

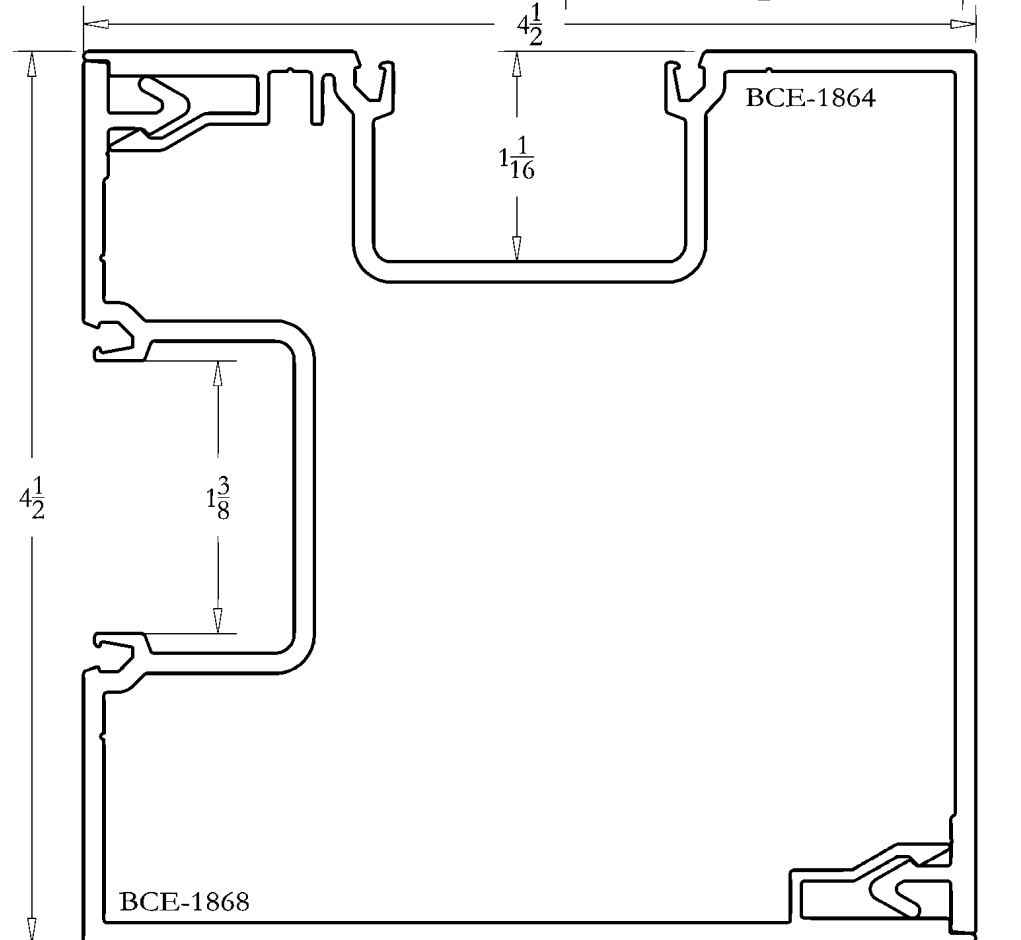
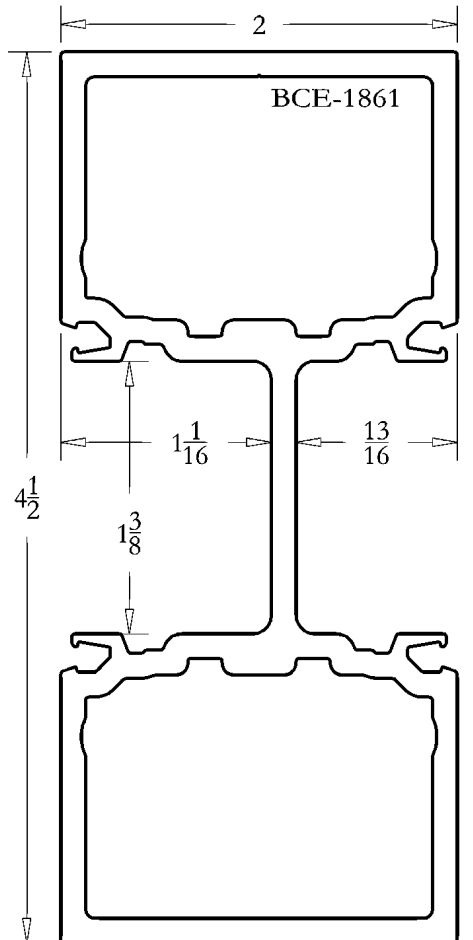
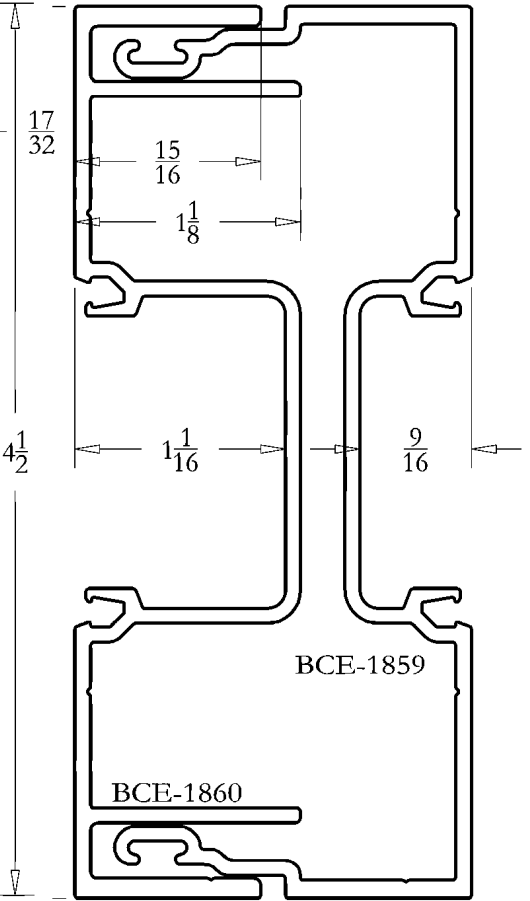
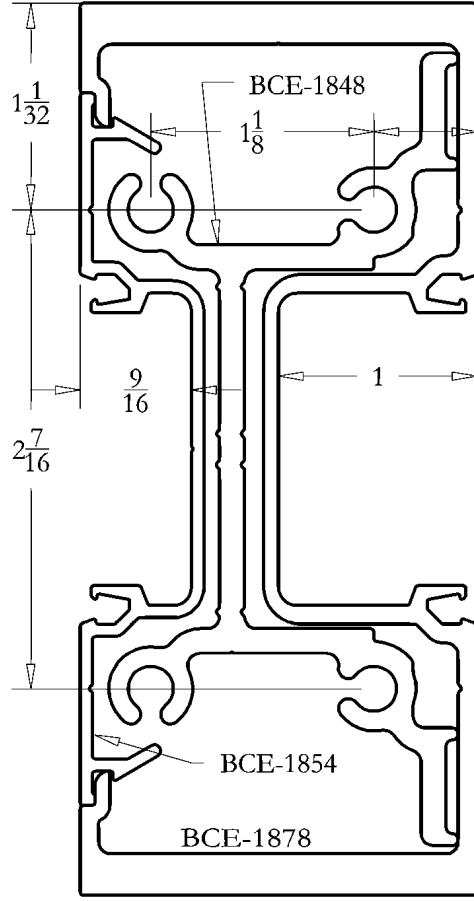
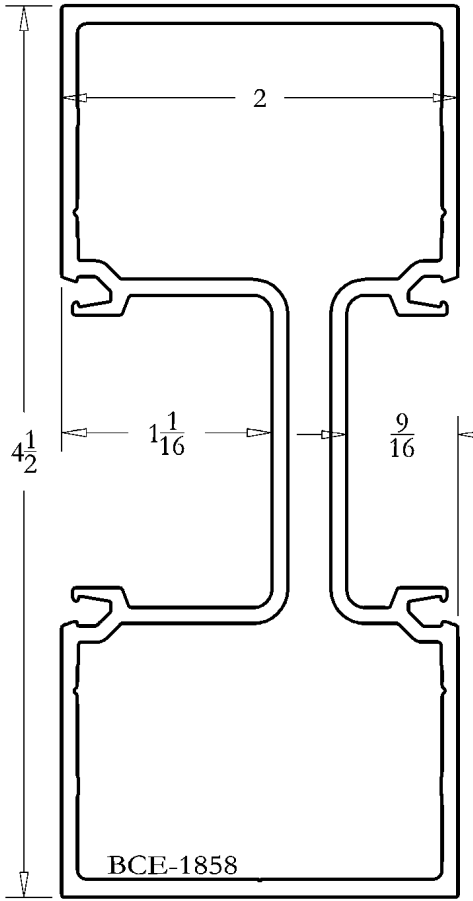

FULL SIZE DETAILS

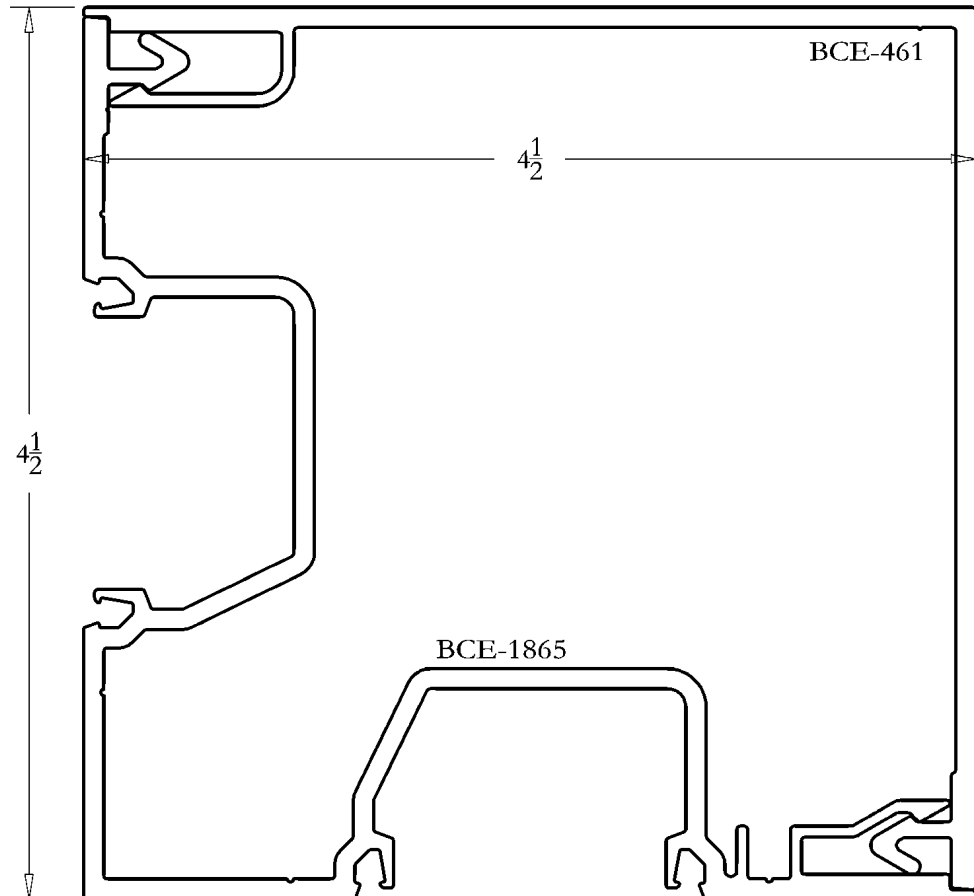
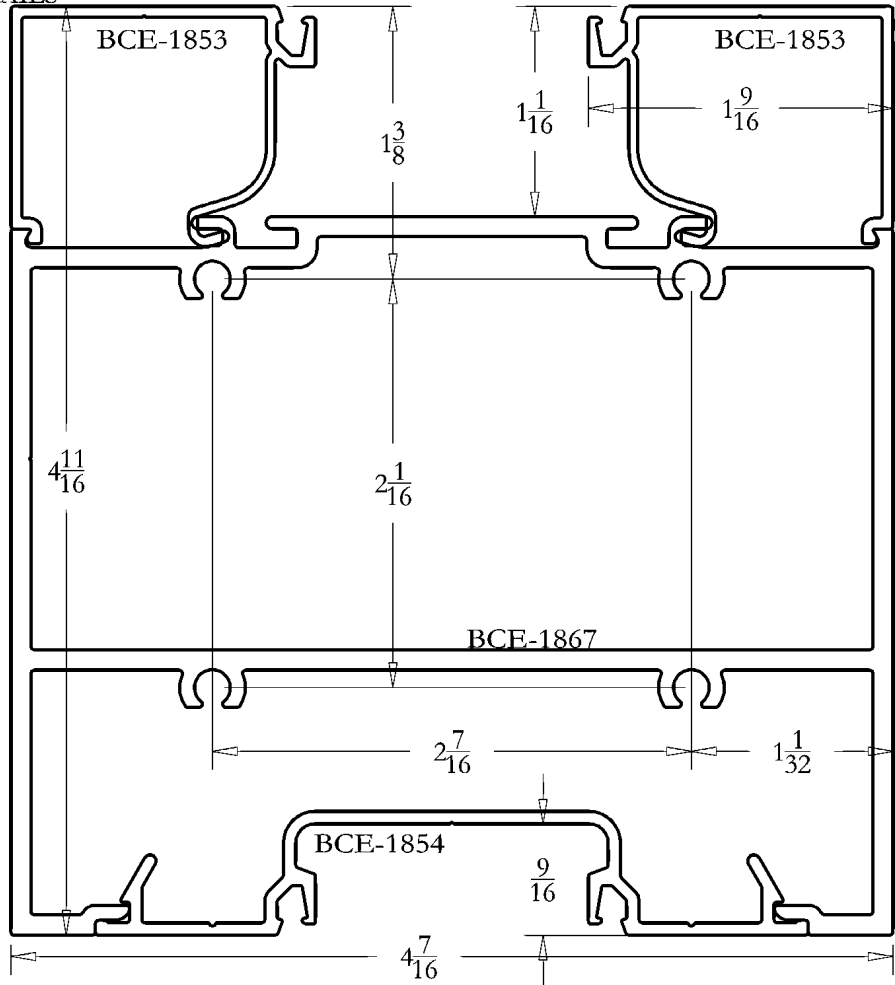

DETAIL SHEET
2" x 4 1/2" FLUSH GLAZED
BCE-1850 SERIES

FULL SIZE DETAILS

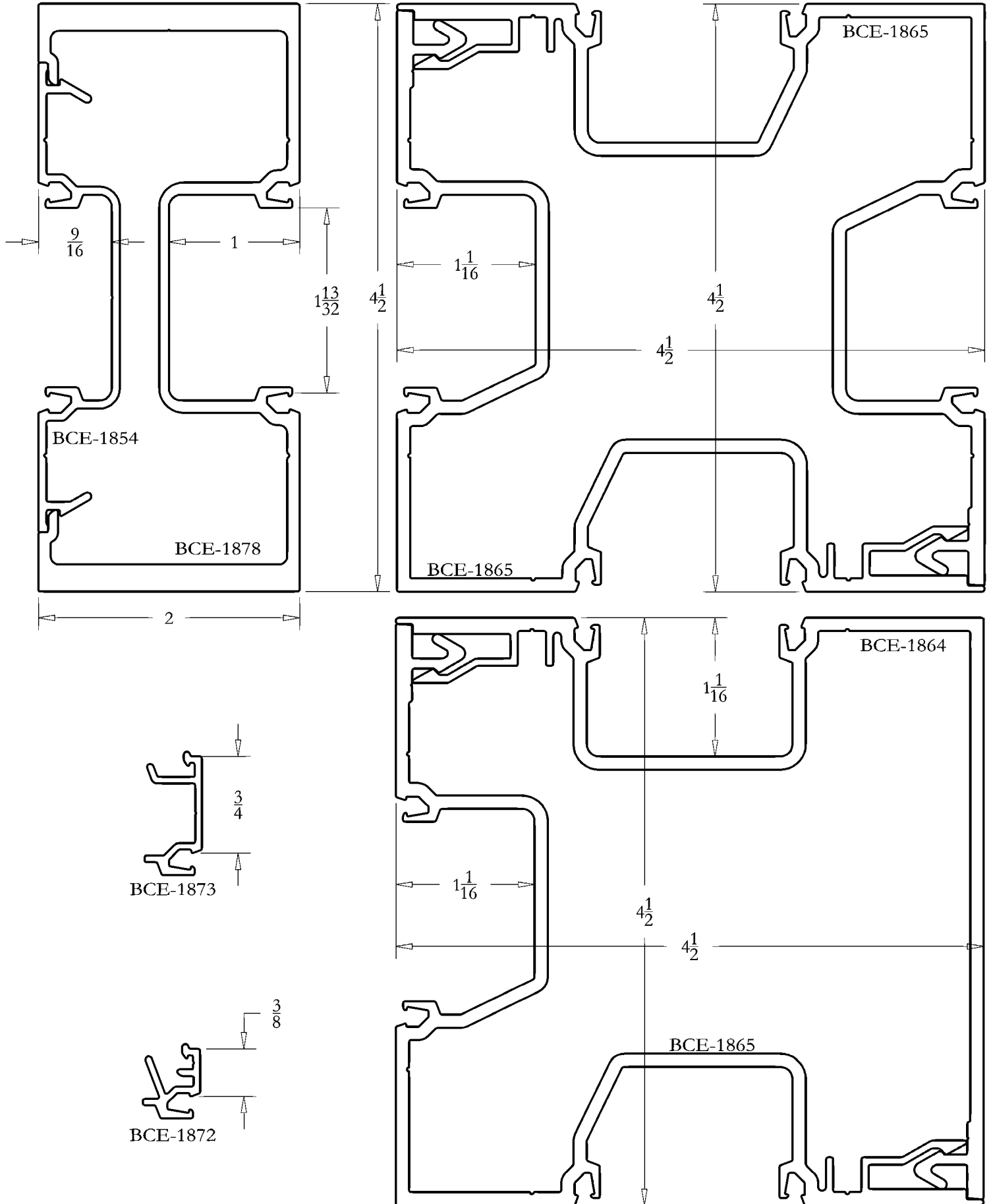

FULL SIZE DETAILS

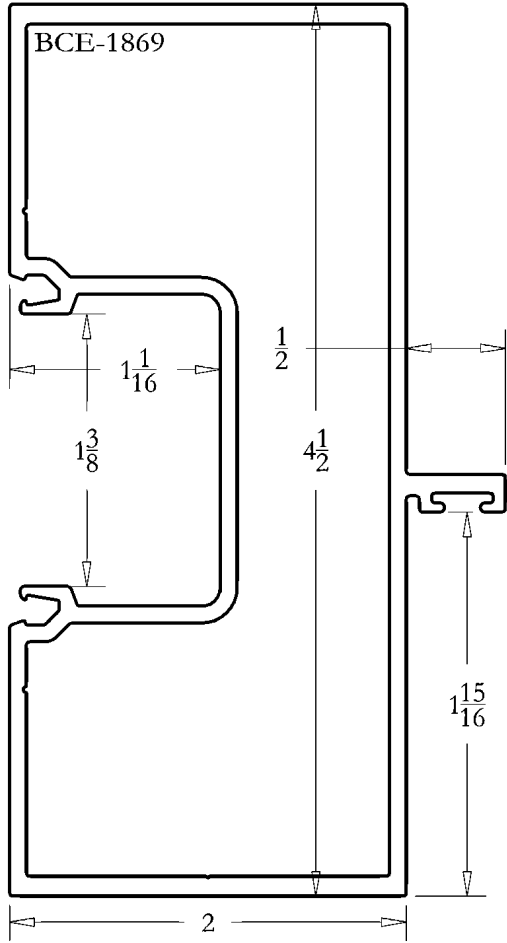

NOTE: IN THE EVENT BCE-1863 DOES NOT SNAP IN PLACE, IT IS UP TO THE INSTALLING MECHANIC TO DEFORM THE SNAP OR TO SILICONE THE COVER INTO PLACE.

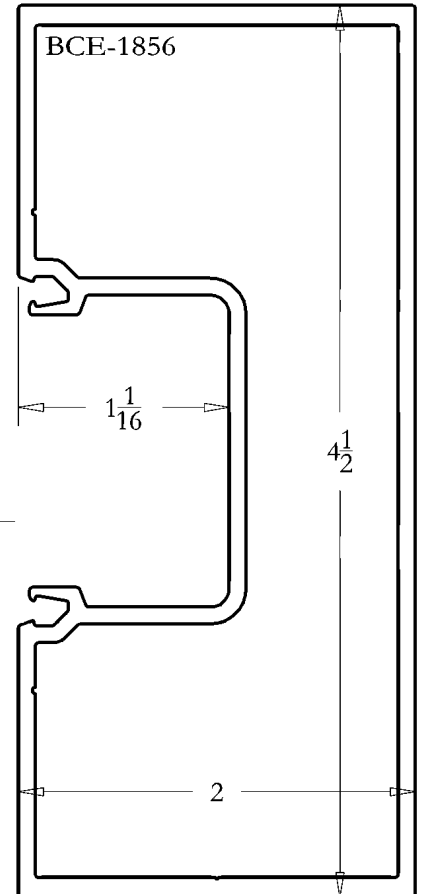
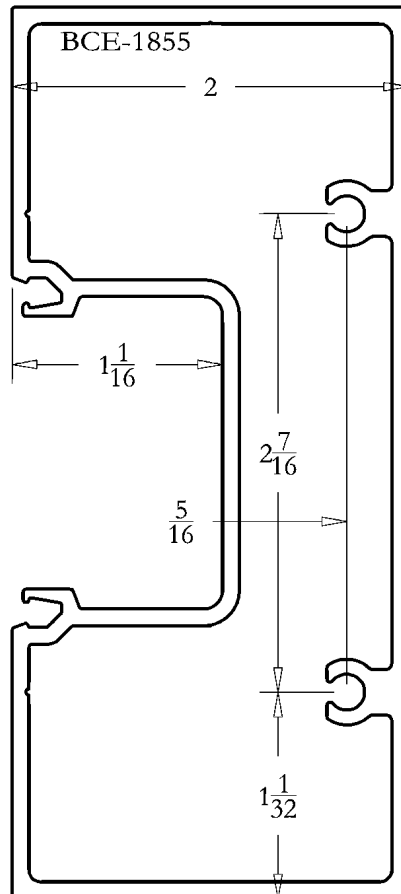
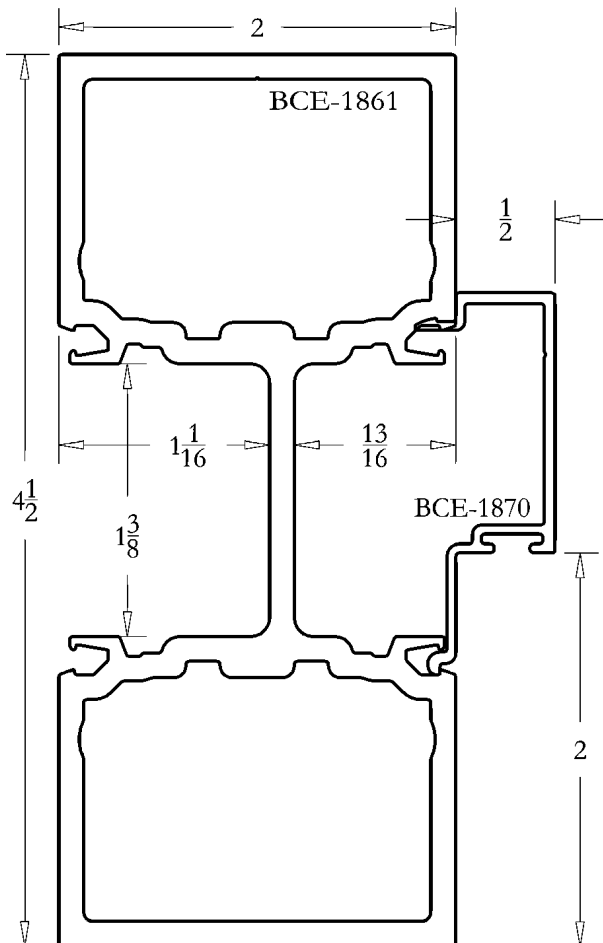
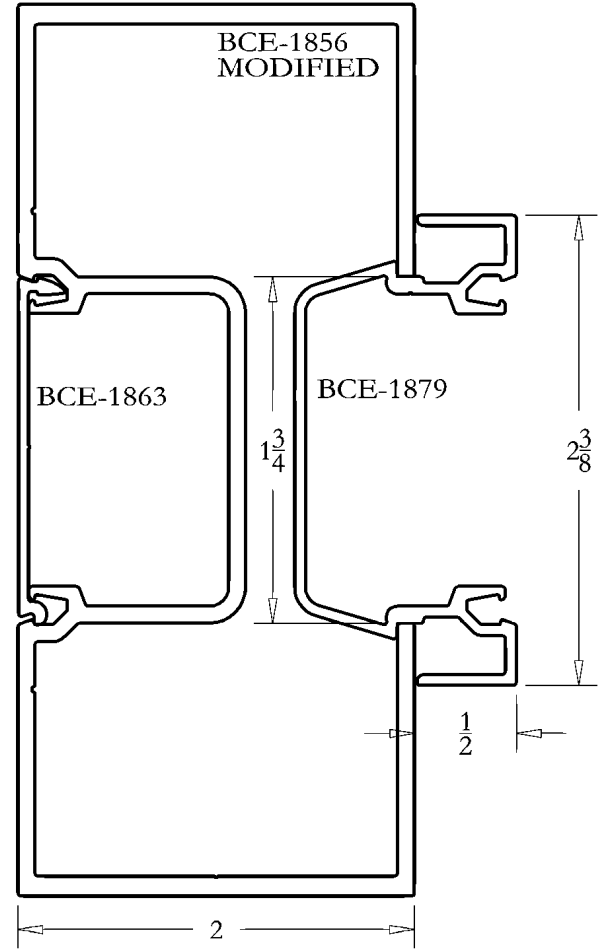
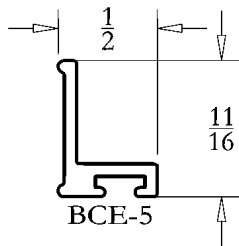

DETAIL SHEET
2" x 4 1/2" FLUSH GLAZED
BCE-1850 SERIES

FULL SIZE DETAILS

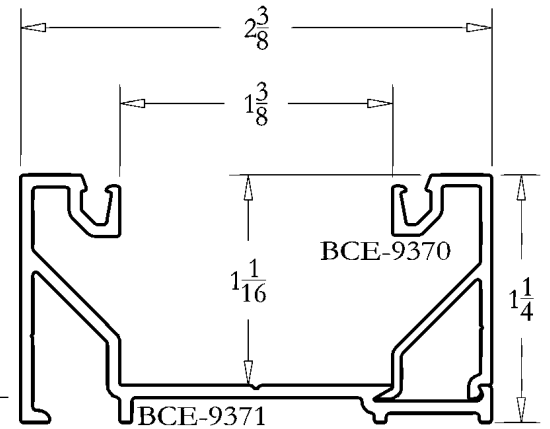
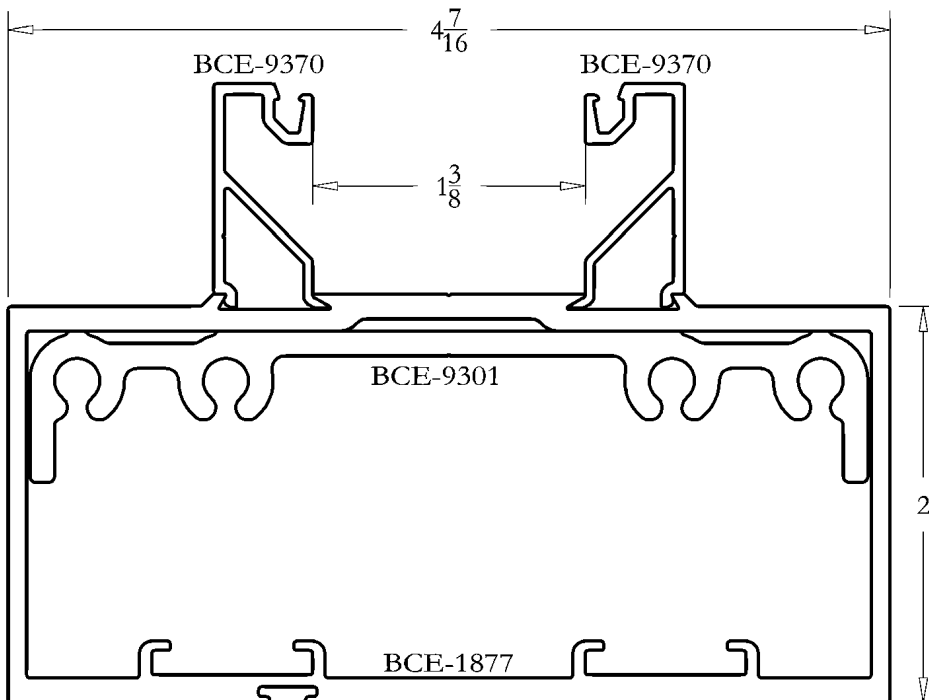
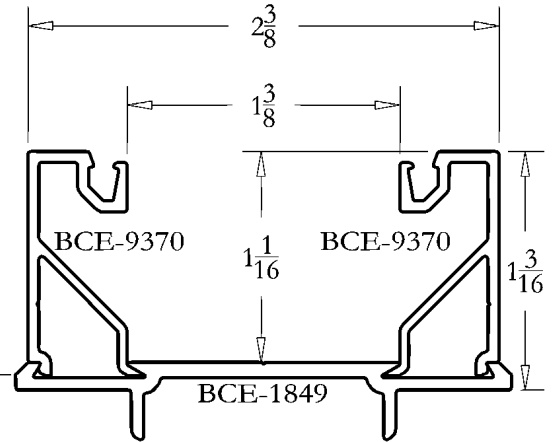
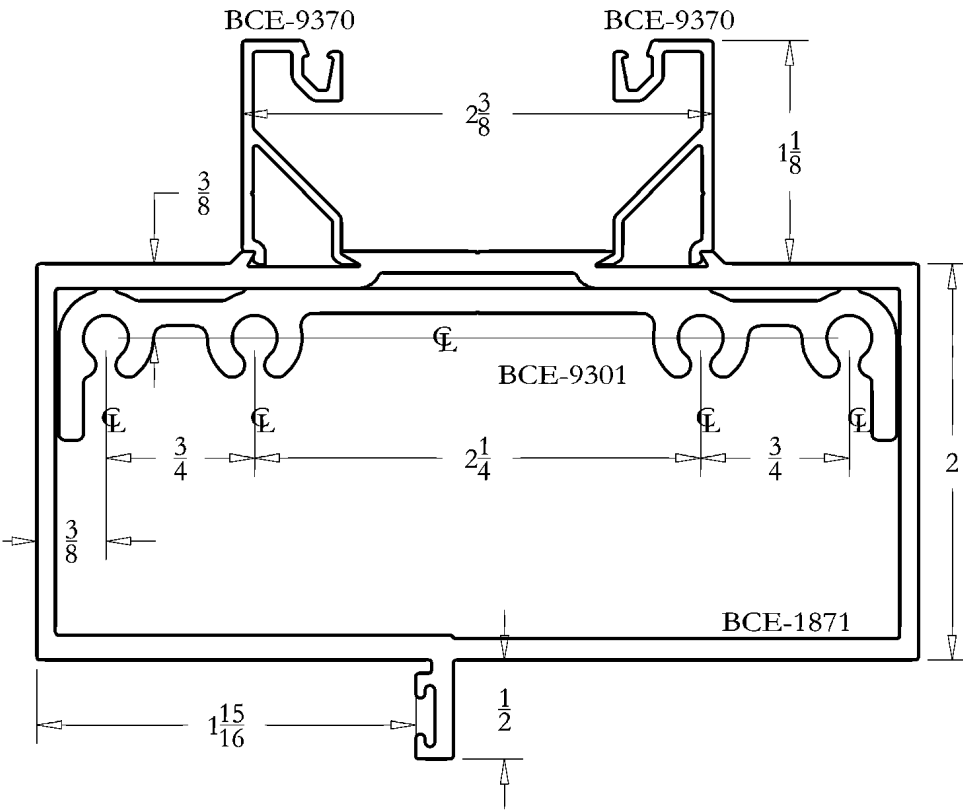

FULL SIZE DETAILS

